

Warranty	5
WARNINGS	6
Safety Symbols	6
Declaration of Conformity	7
Reader Comment Sheet	9
Chapter 1. Getting Started with the HP E1352A	11
Using This Chapter	11
FET Multiplexer Module Description	11
Multimeter Connection Points	13
Analog Bus Connector	13
Tree Terminals	13
Switchbox and Scanning Voltmeter Connections	13
Switchbox	14
Scanning Voltmeter	14
Digital Bus and Triggering	15
Programming Language	16
Initial Operation	16
Chapter 2. Configuring the HP E1352A FET Multiplexer Module	17
Using This Chapter	17
Warnings and Cautions	17
Multiplexer Card Numbers	18
Setting the Address Switch	19
Selecting the Interrupt Line Number	20
Setting the Card ID Switch	20
Removing the Low-to-Guard Isolation Jumper	21
Connecting Field Wiring	22
Wiring Guidelines	22
Wiring a Terminal Module	23
Connecting Multimeters and Signal Generators	24
Connecting User Inputs	25
Chapter 3. Using the HP E1352A FET Multiplexer Module	27
Using This Chapter	27
Selecting Channels	27
Multiplexer Commands	28
Connecting Switchbox Channels to Tree Terminals for Making Measurements	29
Comments	30
Connecting External Current Sources for Making Ohms Measurements	31
Scanning a Range of Switchbox Channels	32
Example: Making Voltage Measurements by Scanning	32
Example: Making 2-Wire Ohms Measurements by Scanning	33
Example: Making Multiple Scans	33
Example: Making Continuous Scans	35
Downloading a Scan List	35
Scanning a Switchbox without a Downloaded Scan List	36

Scanning a Switchbox with a Downloaded Scan List	37
Scanning Voltmeter Configuration with an HP E1326B	38
Chapter 4. Understanding the HP E1352A FET Multiplexer	39
Using This Chapter	39
Commands for Scanning Switchbox Channels	39
Using Scanning Trigger Sources	39
Scanning with External Instruments	39
Example: Scanning with External Instruments	42
Example: Scanning Using "Trig Out" and "Event In" Ports	43
Example: Scanning Using Stand-Alone Multimeter and Digital Bus Triggering	44
Example: Scanning Using Scanning Voltmeter Configuration and Digital Bus Triggering	45
Using the Scan Complete Bit	46
Example: Scan Complete Monitor	46
Chapter 5. HP E1352A FET Multiplexer Command Reference	47
Using This Chapter	47
Command Types	47
Common Command Format	47
SCPI Command Format	47
Linking Commands	49
SCPI Command Reference	49
ABORt	50
ARM	51
:COUNT	51
:COUNT?	51
DISPlay	52
:MONitor:CARD	52
:MONitor[:STATe]	53
INITiate	54
:CONTinuous	54
:CONTinuous?	55
[:IMMediate]	55
OUTPut	56
[:STATe]	56
[:STATe]?	56
[ROUte:]	57
CLOSe	57
CLOSe?	58
OPEN	58
OPEN?	59
SCAN	59
SCAN:MODE	61
SCAN:MODE?	61
SCAN:PORT	62
SETTling[:TIME]	62
SETTling[:TIME]?	63
STATus	64
:OPERation:ENABle	64

:OPERation[:EVENT]?	64
SYSTem	65
:CDEscription?	65
:CPON	65
:CTYPE?	66
:ERRor?	66
TRIGger	67
[:IMMediate]	67
:SOURce	68
:SOURce?	69
IEEE 488.2 Common Commands	70
Command Quick Reference	71
Appendix A. HP E1352A Specifications	73
Appendix B. HP E1352A Register-Based Programming	75
About This Appendix	75
Register Addressing	75
The Base Address	75
A16 Address Space Outside the Command Module or Mainframe	77
A16 Address Space Inside the Command Module or Mainframe	77
Register Offset	77
Register Descriptions	78
WRITE Registers	78
READ Registers	78
Register Bit Descriptions	80
Manufacturer ID Register	80
Device Type Register	80
Status/Control Register	81
Scan Control Register	82
Scan Channel Delay Register	82
Scan Channel Configuration Register	83
Direct Channel Configuration Register	83
Direct Control Register	84
Executing Commands	85
Appendix C. HP E1352A Multiplexer Error Messages	89

Notes

Certification

Hewlett-Packard Company certifies that this product met its published specifications at the time of shipment from the factory. Hewlett-Packard further certifies that its calibration measurements are traceable to the United States National Institute of Standards and Technology (formerly National Bureau of Standards), to the extent allowed by that organization's calibration facility, and to the calibration facilities of other International Standards Organization members.

Warranty

This Hewlett-Packard product is warranted against defects in materials and workmanship for a period of three years from date of shipment. Duration and conditions of warranty for this product may be superseded when the product is integrated into (becomes a part of) other HP products. During the warranty period, Hewlett-Packard Company will, at its option, either repair or replace products which prove to be defective.

For warranty service or repair, this product must be returned to a service facility designated by Hewlett-Packard (HP). Buyer shall prepay shipping charges to HP and HP shall pay shipping charges to return the product to Buyer. However, Buyer shall pay all shipping charges, duties, and taxes for products returned to HP from another country.

HP warrants that its software and firmware designated by HP for use with a product will execute its programming instructions when properly installed on that product. HP does not warrant that the operation of the product, or software, or firmware will be uninterrupted or error free.

Limitation Of Warranty

The foregoing warranty shall not apply to defects resulting from improper or inadequate maintenance by Buyer, Buyer-supplied products or interfacing, unauthorized modification or misuse, operation outside of the environmental specifications for the product, or improper site preparation or maintenance.

The design and implementation of any circuit on this product is the sole responsibility of the Buyer. HP does not warrant the Buyer's circuitry or malfunctions of HP products that result from the Buyer's circuitry. In addition, HP does not warrant any damage that occurs as a result of the Buyer's circuit or any defects that result from Buyer-supplied products.

NO OTHER WARRANTY IS EXPRESSED OR IMPLIED. HP SPECIFICALLY DISCLAIMS THE IMPLIED WARRANTIES OF MERCHANTABILITY AND FITNESS FOR A PARTICULAR PURPOSE.

Exclusive Remedies

THE REMEDIES PROVIDED HEREIN ARE BUYER'S SOLE AND EXCLUSIVE REMEDIES. HP SHALL NOT BE LIABLE FOR ANY DIRECT, INDIRECT, SPECIAL, INCIDENTAL, OR CONSEQUENTIAL DAMAGES, WHETHER BASED ON CONTRACT, TORT, OR ANY OTHER LEGAL THEORY.

Notice

The information contained in this document is subject to change without notice. HEWLETT-PACKARD (HP) MAKES NO WARRANTY OF ANY KIND WITH REGARD TO THIS MATERIAL, INCLUDING, BUT NOT LIMITED TO, THE IMPLIED WARRANTIES OF MERCHANTABILITY AND FITNESS FOR A PARTICULAR PURPOSE. HP shall not be liable for errors contained herein or for incidental or consequential damages in connection with the furnishing, performance or use of this material. This document contains proprietary information which is protected by copyright. All rights are reserved. No part of this document may be photocopied, reproduced, or translated to another language without the prior written consent of Hewlett-Packard Company. HP assumes no responsibility for the use or reliability of its software on equipment that is not furnished by HP.

Restricted Rights Legend

Use, duplication or disclosure by the U.S. Government is subject to restrictions as set forth in subparagraph (c)(1)(ii) of the Rights in Technical Data and Computer Software clause in DFARS 252.227-7013.

Hewlett-Packard Company
3000 Hanover Street
Palo Alto, California 94304 U.S.A.

Rights for non-DOD U.S. Government Departments and Agencies are as set forth in FAR 52.227-19 (c) (1,2).



HP E1352A 32-Channel Single-Ended FET Multiplexer Module User's Manual
Edition 2

Copyright © 1995 Hewlett-Packard Company. All Rights Reserved.

Documentation History

All Editions and Updates of this manual and their creation date are listed below. The first Edition of the manual is Edition 1. The Edition number increments by 1 whenever the manual is revised. Updates, which are issued between Editions, contain replacement pages to correct or add additional information to the current Edition of the manual. Whenever a new Edition is created, it will contain all of the Update information for the previous Edition. Each new Edition or Update also includes a revised copy of this documentation history page.

Edition 1 August 1990
Edition 2 July 1995

Safety Symbols



Instruction manual symbol affixed to product. Indicates that the user must refer to the manual for specific WARNING or CAUTION information to avoid personal injury or damage to the product.



Indicates the field wiring terminal that must be connected to earth ground before operating the equipment—protects against electrical shock in case of fault.

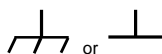

Frame or chassis ground terminal—typically connects to the equipment's metal frame.



Alternating current (AC).



Direct current (DC).



Indicates hazardous voltages.

WARNING

Calls attention to a procedure, practice, or condition that could cause bodily injury or death.

CAUTION

Calls attention to a procedure, practice, or condition that could possibly cause damage to equipment or permanent loss of data.

WARNINGS

The following general safety precautions must be observed during all phases of operation, service, and repair of this product. Failure to comply with these precautions or with specific warnings elsewhere in this manual violates safety standards of design, manufacture, and intended use of the product. Hewlett-Packard Company assumes no liability for the customer's failure to comply with these requirements.

Ground the equipment: For Safety Class 1 equipment (equipment having a protective earth terminal), an uninterruptible safety earth ground must be provided from the mains power source to the product input wiring terminals or supplied power cable.

DO NOT operate the product in an explosive atmosphere or in the presence of flammable gases or fumes.

For continued protection against fire, replace the line fuse(s) only with fuse(s) of the same voltage and current rating and type. DO NOT use repaired fuses or short-circuited fuse holders.

Keep away from live circuits: Operating personnel must not remove equipment covers or shields. Procedures involving the removal of covers or shields are for use by service-trained personnel only. Under certain conditions, dangerous voltages may exist even with the equipment switched off. To avoid dangerous electrical shock, DO NOT perform procedures involving cover or shield removal unless you are qualified to do so.

DO NOT operate damaged equipment: Whenever it is possible that the safety protection features built into this product have been impaired, either through physical damage, excessive moisture, or any other reason, REMOVE POWER and do not use the product until safe operation can be verified by service-trained personnel. If necessary, return the product to a Hewlett-Packard Sales and Service Office for service and repair to ensure that safety features are maintained.

DO NOT service or adjust alone: Do not attempt internal service or adjustment unless another person, capable of rendering first aid and resuscitation, is present.

DO NOT substitute parts or modify equipment: Because of the danger of introducing additional hazards, do not install substitute parts or perform any unauthorized modification to the product. Return the product to a Hewlett-Packard Sales and Service Office for service and repair to ensure that safety features are maintained.

Declaration of Conformity
according to ISO/IEC Guide 22 and EN 45014

Manufacturer's Name: Hewlett-Packard Company
Loveland Manufacturing Center

Manufacturer's Address: 815 14th Street S.W.
Loveland, Colorado 80537

declares, that the product:

Product Name: 32-Channel Single-Ended FET Multiplexer Module

Model Number: E1352A

Product Options: All

conforms to the following Product Specifications:

Safety: IEC 1010-1 (1990) Incl. Amend 1 (1992)/EN61010-1 (1993)
CSA C22.2 #1010.1 (1992)
UL 1244

EMC: CISPR 11:1990/EN55011 (1991): Group1 Class A
IEC 801-2:1991/EN50082-1 (1992): 4kVCD, 8kVAD
IEC 801-3:1984/EN50082-1 (1992): 3 V/m
IEC 801-4:1988/EN50082-1 (1992): 1kV Power Line

Supplementary Information: The product herewith complies with the requirements of the Low Voltage Directive 73/23/EEC and the EMC Directive 89/336/EEC and carries the CE-marking accordingly.

Tested in a typical configuration in an HP B-Size VXI mainframe.

July 20, 1995



Jim White, QA Manager

European contact: Your local Hewlett-Packard Sales and Service Office or Hewlett-Packard GmbH, Department HQ-TRE, Herrenberger Straße 130, D-71034 Böblingen, Germany (FAX +49-7031-14-3143).

Notes

Please fold and tape for mailing

Reader Comment Sheet

HP E1352A 32-Channel Single-Ended FET Multiplexer Module User's Manual
Edition 2

You can help us improve our manuals by sharing your comments and suggestions. **In appreciation of your time, we will enter you in a quarterly drawing for a Hewlett-Packard Palmtop Personal Computer** (U.S. government employees cannot participate in the drawing).

_____ Your Name	_____ City, State/Province
_____ Company Name	_____ Country
_____ Job Title	_____ Zip/Postal Code
_____ Address	_____ Telephone Number with Area Code

Please list the system controller, operating system, programming language, and plug-in modules you are using.

fold here

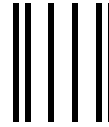

NO POSTAGE NECESSARY IF MAILED IN THE UNITED STATES

BUSINESS REPLY MAIL
FIRST CLASS PERMIT NO. 37 LOVELAND, CO

POSTAGE WILL BE PAID BY ADDRESSEE

HEWLETT-PACKARD COMPANY
 Measurement Systems Division
 Learning Products Department
 P.O. Box 301
 Loveland, CO 80539-9984

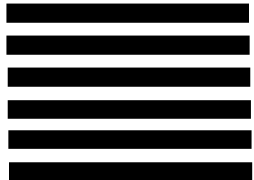

cut along this line



fold here

Please pencil-in one circle for each statement below:

- The documentation is well organized.
- Instructions are easy to understand.
- The documentation is clearly written.
- Examples are clear and useful.
- Illustrations are clear and helpful.
- The documentation meets my overall expectations.

	Disagree	←	→	Agree
•	<input type="radio"/>	<input type="radio"/>	<input type="radio"/>	<input type="radio"/>
•	<input type="radio"/>	<input type="radio"/>	<input type="radio"/>	<input type="radio"/>
•	<input type="radio"/>	<input type="radio"/>	<input type="radio"/>	<input type="radio"/>
•	<input type="radio"/>	<input type="radio"/>	<input type="radio"/>	<input type="radio"/>
•	<input type="radio"/>	<input type="radio"/>	<input type="radio"/>	<input type="radio"/>
•	<input type="radio"/>	<input type="radio"/>	<input type="radio"/>	<input type="radio"/>

Please write any comments or suggestions below--be specific.

Using This Chapter

This chapter describes the HP E1352A 32-Channel Single-Ended FET Multiplexer Module, and shows how to program the module using SCPI (Standard Commands for Programmable Instruments) commands. This chapter contains the following sections:

- FET Multiplexer Module Description Page 11
- Multimeter Connection Points Page 13
- Switchbox & Scanning Voltmeter Configurations Page 13
- Digital Bus and Triggering Page 15
- Programming Language Page 16
- Initial Operation Page 16

FET Multiplexer Module Description

The FET multiplexer module provides high-speed switching (multiplexing) for up to 32 channels. The module can be used as a scanning multiplexer for a scanning voltmeter configuration, or as a stand-alone multiplexer in a switchbox configuration. The channels are numbered 00 to 31. Each channel provides a connection for High (H). Low (L) and Guard (G) are common for all channels. The FET multiplexer module can switch up to 100,000 connections per second (100 K switches/sec).

The FET multiplexer module consists of a component assembly and a terminal module. There are three different terminal modules, one for each of the following applications: HP E1351A 16-Channel FET Multiplexer Module, HP E1353A 16-Channel Thermocouple FET Multiplexer Module, and HP E1352A 32-Channel Single-Ended FET Multiplexer Module. The component assembly is the same for all three applications. For information on the 16-Channel FET Multiplexer Module, see the *HP E1351A/E1353A User's Manual*.

The component assembly contains the VXIbus interface, the FET switches, the analog bus connector and the digital bus. The terminal modules provide connection points for the individual channels as well as monitoring points for the three terminals. The FET multiplexer module can be externally triggered from the VXIbus backplane or through the digital bus handshake lines on the front of the component assembly.

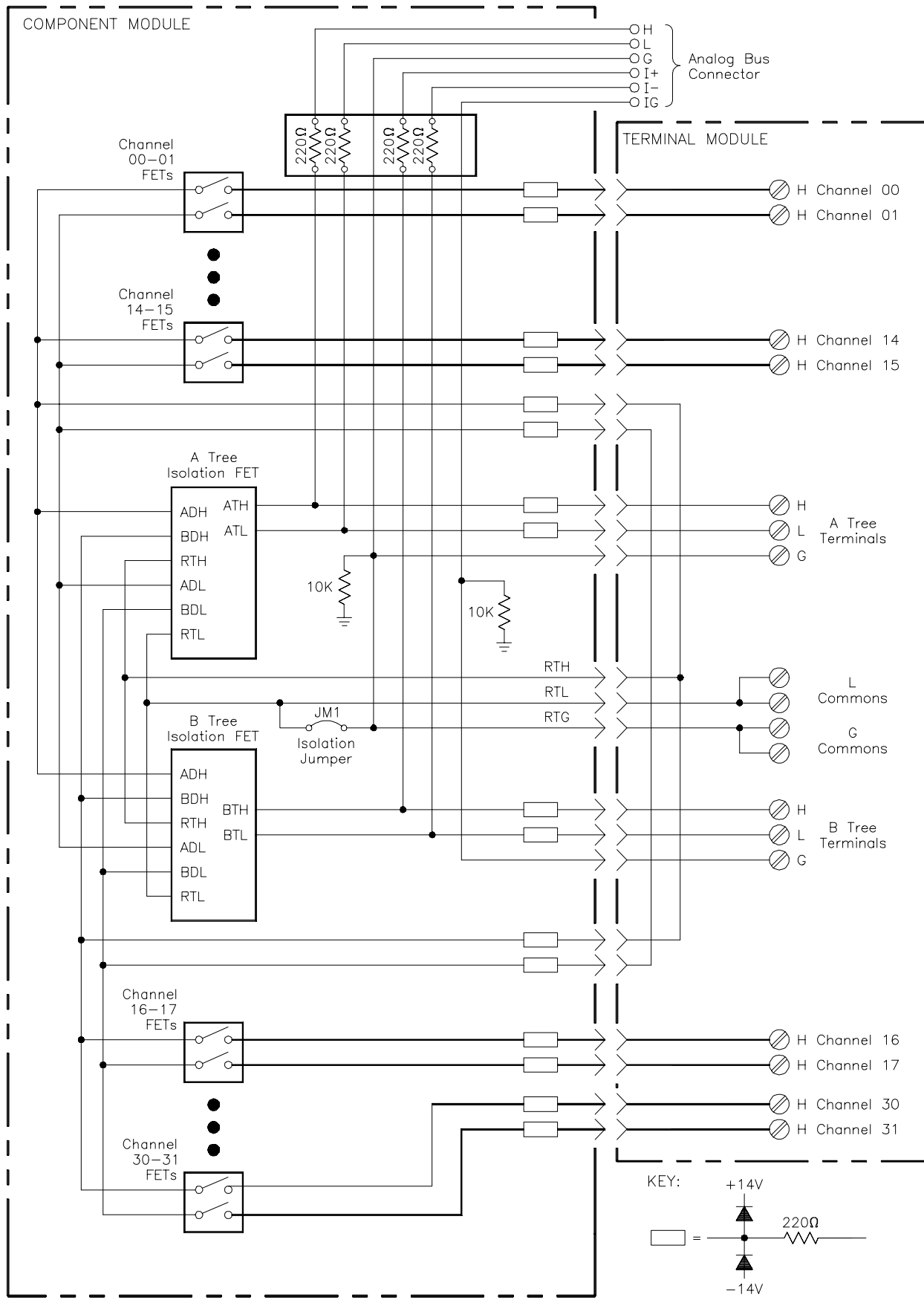

Figure 1-1. FET Multiplexer Module Block Diagram

For high-speed operation (100 K switches/sec.) the scanning list is automatically downloaded into RAM on the multiplexer module. Triggering for channel advance is from the two handshake lines on the Digital Bus. The scanning operation does not require any intervention from the mainframe CPU. This only applies for switchboxes or scanning voltmeter configurations that have all FET multiplexer modules. For a downloaded scan list in switchboxes, the trigger source must be TRIG:SOUR DBUS or TRIG:SOUR IMM.

Multimeter Connection Points

Multimeters can be connected to the 32-Channel Single-Ended FET Multiplexer Module with the analog bus connector or through the tree terminals. For a scanning voltmeter configuration the analog bus connector is generally used, and for stand-alone multimeters the tree terminals are used.

Analog Bus Connector

The analog bus connector provides a direct connection between multiple multiplexer modules and also between a multiplexer module and HP E1326/E1411 Multimeters. A ribbon cable is used to daisy-chain multiple multiplexer modules together, and to connect a multimeter to the multiplexer modules for a scanning voltmeter configuration. The SCAN:PORT ABUS command automatically closes the appropriate tree isolation switches to route closed channels to the analog bus. This command must be executed in a switchbox configuration. A scanning voltmeter automatically configures the multiplexer for the analog bus connector.

Tree Terminals

Tree terminals provide an external connection point through the terminal modules for the signals which are on the analog bus lines. Tree terminals are the recommended connection points for connecting stand-alone multimeters and external current sources for resistance measurements.

Switchbox and Scanning Voltmeter Connections

A VXibus instrument is a module or group of modules which perform a specified function. For the HP E1300/01 mainframe, the first module in an instrument must have a logical address which is evenly divisible by 8 (16, 24, 112), and the rest of the modules in the instrument are numbered consecutively. The instrument's secondary address is the whole number equal to the logical address divided by 8 (for a logical address of 16, 17, 18,...23, the secondary address is 02). For instrument definition in other mainframes, see the mainframe manual. If an instrument consists of only multiplexer modules, it is a switchbox configuration. If a multiplexer module(s) is combined with a multimeter to form an instrument, that is a scanning voltmeter configuration.

Switchbox

A switchbox is a multiplexer module or group of multiplexer modules which form a single instrument. A switchbox can be connected to a multimeter which is a different VXIbus instrument, to an HP-IB¹ controlled multimeter, or to a stand-alone multimeter. The switchbox and the multimeter have different secondary addresses. Separate configuration commands must be sent to the switchbox and to the multimeter. The following program illustrates the different addresses and the configuration commands required. The HP-IB interface select code is 7, and the mainframe address is 09. The multiplexer has an instrument address of 24, so its secondary address is 03. The multimeter is HP-IB controlled, and has a primary address of 22.

```
10 OUTPUT 722;"TRIG EXT;DC 10"      !Sets multimeter to external trigger
                                     and to measure DC volts
20 OUTPUT 70903;"OUTP ON"           !Enables "Trig Out" port
30 OUTPUT 70903;"TRIG:SOUR BUS"     !Sets switchbox to receive bus
                                     triggers
40 OUTPUT 70903;"SCAN:MODE VOLT"    !Set up switchbox for voltage
                                     measurements
50 OUTPUT 70903;"SCAN:PORT ABUS"    !Closes the appropriate tree
                                     isolation switches while scanning,
                                     automatically makes connection to
                                     the analog bus and tree terminals
60 OUTPUT 70903;"ARM:COUN 2"        !Set for two cycles through the
                                     scan list
70 OUTPUT 70903;"SCAN (@100;131)"  !Selects the channel list. 100
                                     selects first channel on card 1;
                                     131 selects last channel on card 1
80 OUTPUT 70903;"INIT"              !Close first channel to start
                                     scanning cycle
90 FOR I = 1 TO 32                   !Start count loop
100 ENTER 722;A                      !Enter reading into variable A
110 PRINT A                          !Print reading in variable A
120 TRIGGER 70903                    !Trigger the switchbox to advance
                                     the channel list
130 NEXT I                            !Increment count
140 END
```

Scanning Voltmeter

When the multiplexer(s) is combined with a multimeter to form a single instrument, they become a virtual instrument, a scanning voltmeter. The multiplexer(s) and the multimeter have the same secondary address. The multimeter automatically configures the multiplexer, so the SCAN:MODE, SCAN:PORT and TRIG:SOUR commands are not required. Channel advance is from the digital bus handshake lines, so the count loop is not required. The ARM:COUN command does not apply to downloaded scan lists, so you cannot specify the number of cycles through the scan list. You can, however, specify INIT:CONT ON for continuous scanning through the scan list.

¹ HP-IB is Hewlett-Packard's implementation of IEEE Std 488.1-1978

```

10 DIM Rdgs(1:32)                                !Dimension an array for 32
                                                readings
20 OUTPUT 70903;"RST"                            !Reset instrument
30 OUTPUT 70903;"MEAS:VOLT:DC? (@100:131)"!Configure instrument
40 ENTER 70903;Rdgs(*)                          !Enter readings into array
50 PRINT Rdgs(*)                                !Print results
60 END

```

Digital Bus and Triggering

The HP E1352A can be triggered for channel advance from the VXIbus backplane or through the digital bus handshake cable on the front of the component assembly. Backplane triggering can come from HP-IB computer commands over the HP-IB Bus or from the HP E1300/1301 Mainframe "Event In" port. Digital bus triggering uses two handshake lines; channel advance and channel closed. Channel advance (input to multiplexer) triggers an advance, and channel closed (output from multiplexer) signifies advance completed.

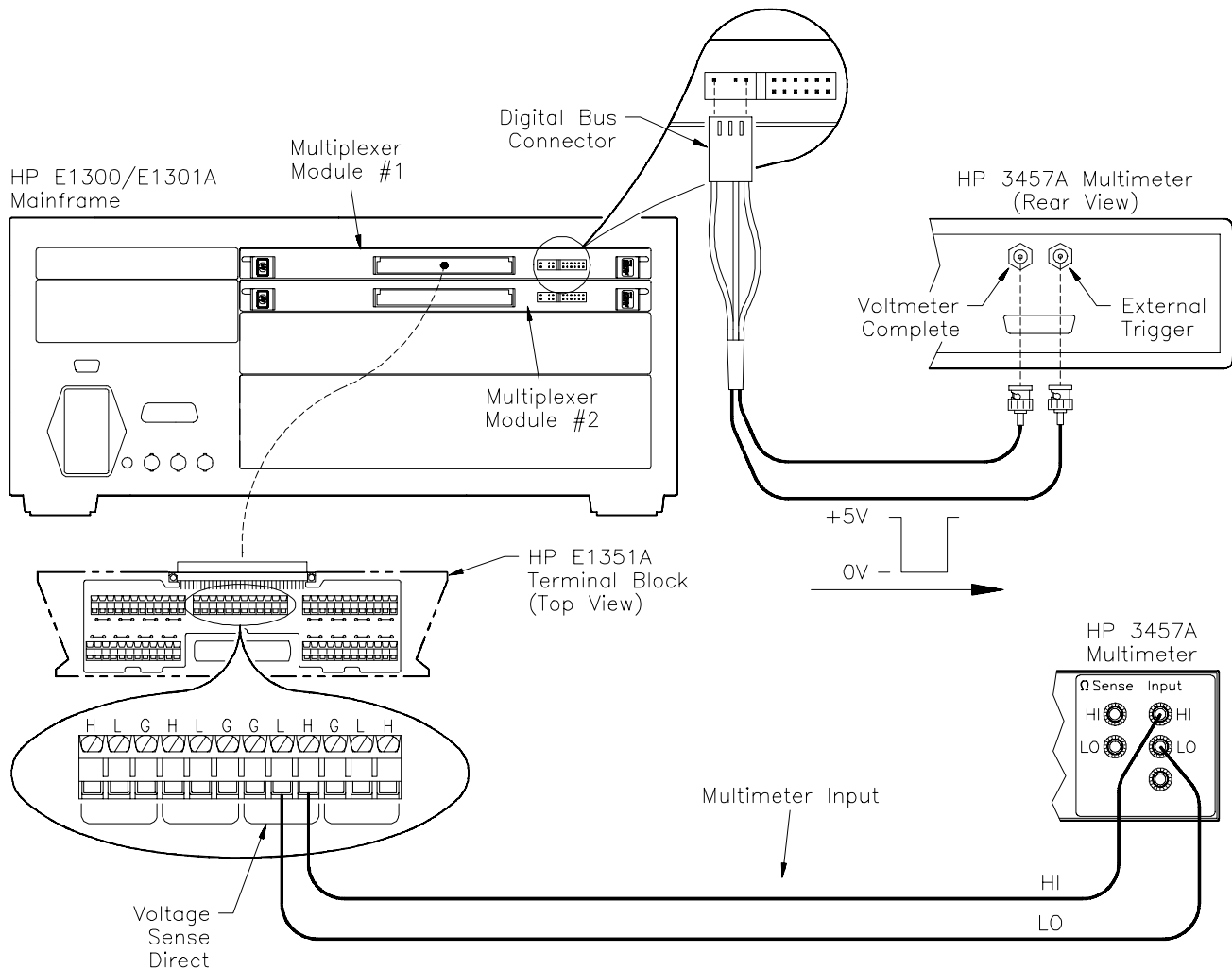

Figure 1-2. Custom Cable for Digital Bus Triggering

The HP E1326B multimeter has a digital bus port on the face plate and connects to the multiplexer with the digital bus cable (see Figure 1-2). To connect other multimeters for digital bus triggering, you must prepare custom cables. Use a connector like the one on the digital bus cable (HP part number E1300-61611). Connect the measurement complete port from the multimeter to the channel advance pin, and the external trigger to the channel closed pin. Connect the grounds for both signals to the Digital Bus ground (second pin from right). You can use this cable to connect an external multimeter to a switchbox, and then use TRIG:SOUR DBUS (digital bus triggering). You can also order a custom cable with BNC to digital bus connectors, HP part number E1411-80001.

Programming Language

The examples in this manual use the Standard Commands for Programmable Instruments (SCPI) commands, Hewlett-Packard BASIC and an HP 9000 Series 200/300 computer over the HP-IB. Chapter 5 contains information on SCPI command format. Appendix B contains details on the registers for register-based programming.

Initial Operation

Use the following program to verify initial multiplexer operation by closing a channel and querying channel closure. The computer interfaces to the mainframe with the Hewlett-Packard Interface Bus (HP-IB). The HP-IB interface select code is 7, and the mainframe address is 09. The multiplexer has an instrument address of 24, so its secondary address is 03.

This example first resets the switchbox and then closes channel 02 of a single multiplexer module (card number 1) in the switchbox. The program next queries the channel closure state. A returned "1" shows that the channel is closed, a returned "0" designates an open channel.

```
10 OUTPUT 70903;"*RST"           !Opens all channels
20 OUTPUT 70903;"CLOS (@102)"    !Close channel 02 on card 1
30 OUTPUT 70903;"CLOS? (@102)"  !Query channel 02 state
40 ENTER 70903;Value            !Enter results into variable called
                                Value
50 PRINT Value                  !Display result
60 END
```

Chapter 2

Configuring the HP E1352A FET Multiplexer Module

Using This Chapter

This chapter shows how to configure the 32-Channel Single-Ended FET Multiplexer Module, how to connect external wiring and how to connect multimeters. This chapter contains the following sections:

- Warnings and Cautions Page 17
- Multiplexer Card Numbers Page 18
- Selecting the Interrupt Line Number Page 20
- Setting the Card ID Switch Page 20
- Removing the Low-to-Guard Isolation Jumper Page 21
- Connecting Field Wiring Page 22
- Connecting Multimeters and Signal Generators Page 24
- Connecting User Inputs Page 25

Warnings and Cautions

Warning **SHOCK HAZARD.** Only service-trained personnel who are aware of the hazards involved should install, remove, or configure the multiplexer modules. Before you install any module, disconnect AC power from the mainframe and from user wiring.

Caution **MAXIMUM VOLTAGE/CURRENT.** The maximum voltage that may be applied between High (H), Low (L), and Guard (G) terminals is 15 V dc or 10.6 V rms (15 V peak). The maximum current is 1 mA per channel.

STATIC ELECTRICITY. Static electricity is a major cause of component failure. To prevent damage to the electrical components in the multiplexer module, observe anti-static techniques whenever removing a module from the mainframe or whenever working on a module.

Multiplexer Card Numbers

HP plug-in modules installed in an HP VXIbus mainframe are treated as independent instruments, each having a unique secondary HP-IB address. An instrument may be composed of a single plug-in module or multiple plug-in modules. The card number identifies the module within a switchbox or scanning voltmeter configuration. The multiplexer module with the lowest logical address is always card number 01. The multiplexer module with the next successive address is 02, and so on. Figure 2-1 illustrates the card numbers and logical addresses of typical single-module switchboxes. Figure 2-2 illustrates the card numbers and logical addresses of a typical multiple-module switchbox. Figure 2-3 illustrates the card numbers of a typical multiple-module scanning voltmeter.

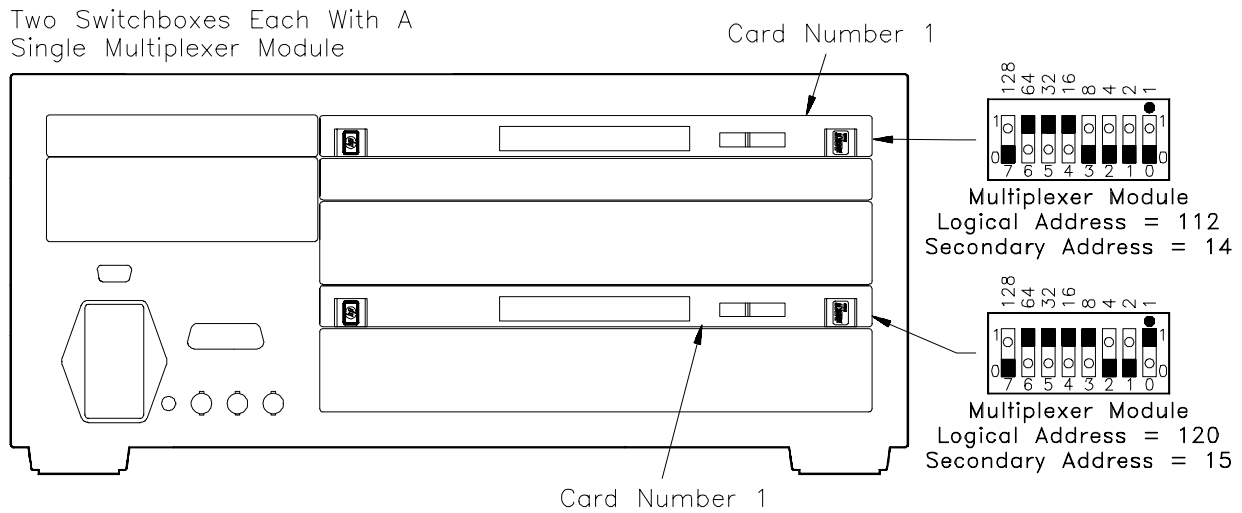

Figure 2-1. Card Numbers for Single-Module Switchbox

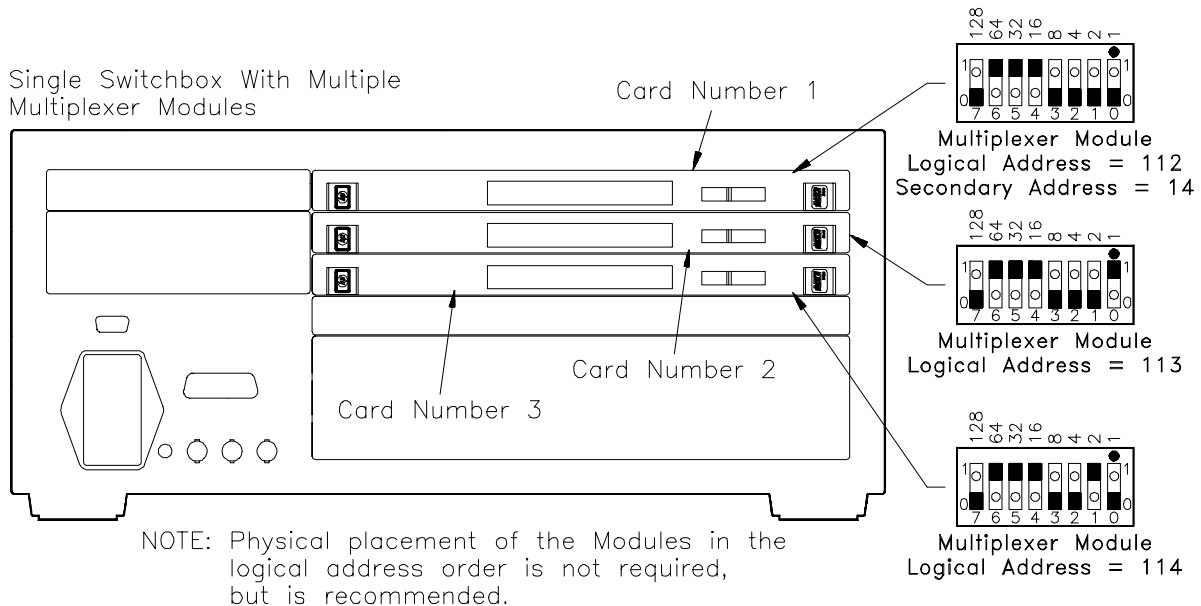

Figure 2-2. Card Numbers for Multiple-Module Switchbox

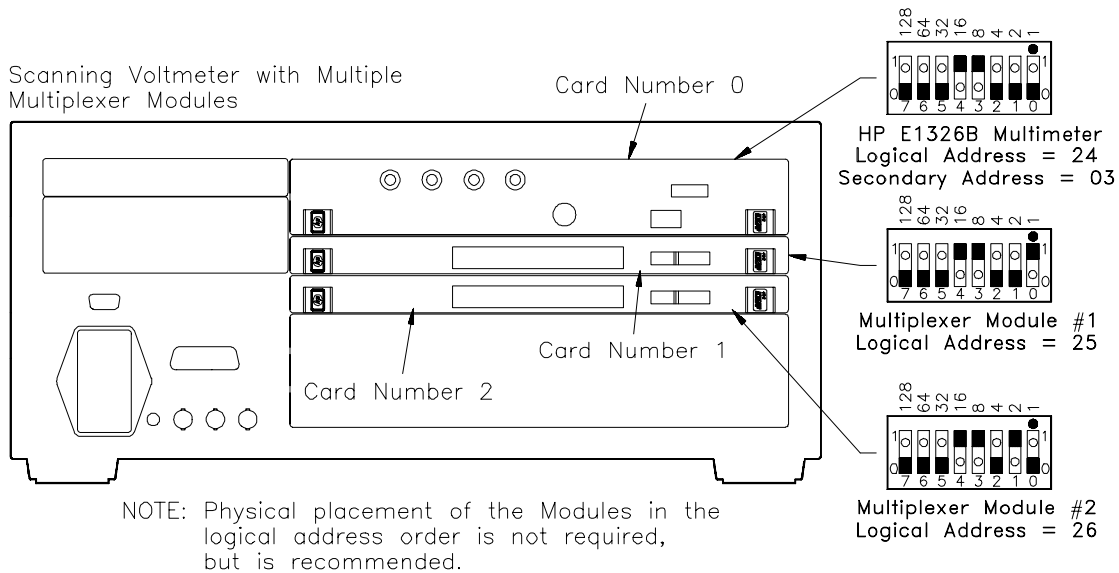

Figure 2-3. Card Numbers for Scanning Voltmeter

The logical addresses noted in Figures 2-1, 2-2, and 2-3 apply to modules installed in an HP 75000 Series B Mainframe (HP model number E1300/E1301) or in a mainframe with an HP E1405/1406 Command Module. See the *HP 75000 Series B Installation and Getting Started Guide* or the appropriate *HP Command Module Manual* for more information on switchboxes and scanning voltmeter configurations, and logical addressing. For uses in other systems or mainframes, see the appropriate manuals.

Setting the Address Switch

The address switch (LADDR) factory setting is 112. You may have changed the setting during module installation. Valid address values are from 1 to 255. Refer to the *HP 75000 Series B System Installation and Getting Started Guide* or the appropriate *HP Command Module Manual* for addressing information. Otherwise, to change the setting, see Figure 2-4.

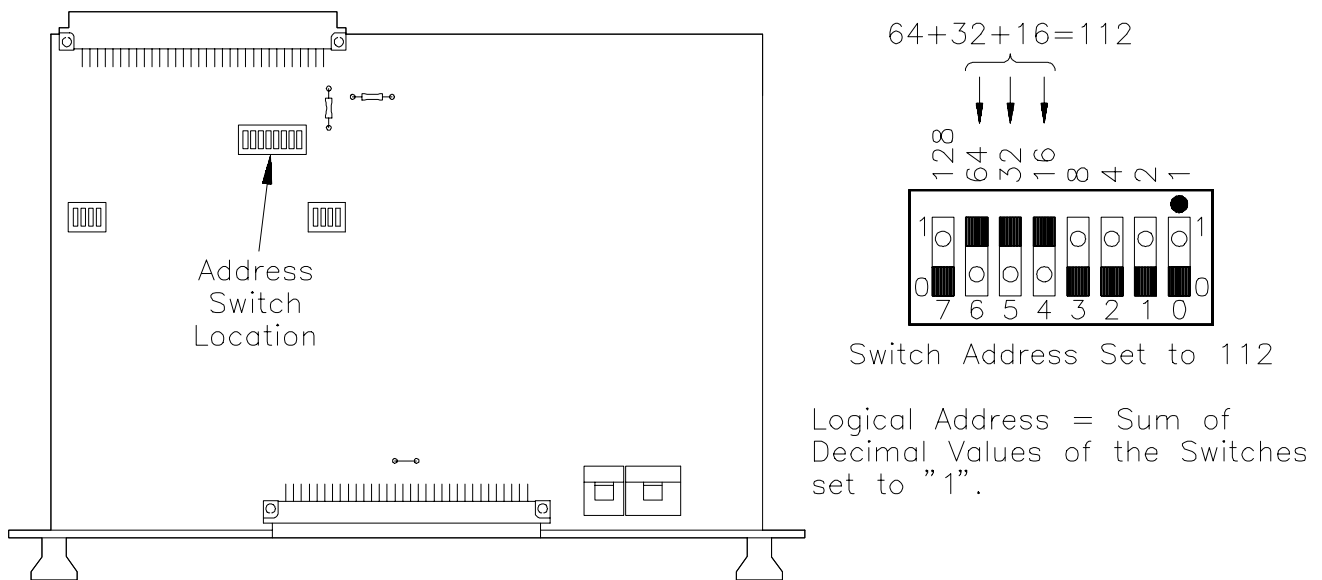

Figure 2-4. Setting the Address Switch

Selecting the Interrupt Line Number

The multiplexer module generates interrupts at the end of a downloaded scan list. The interrupt line number switch determines which backplane IRQ line will be used. Different mainframes and resource managers recognize different backplane IRQ lines. The interrupt line number must be set to the line number your system is programmed to recognize. Refer to your mainframe manual.

Refer to Figure 2-5 to change the interrupt lines. Valid line numbers are from 1 to 7. Set the interrupt line number to the mainframe interrupt handler number.

Switch Setting			
2	1	0	IRQ Line #
0	0	0	= 0
0	0	1	= 1
0	1	0	= 2
0	1	1	= 3
1	0	0	= 4
1	0	1	= 5
1	1	0	= 6
1	1	1	= 7

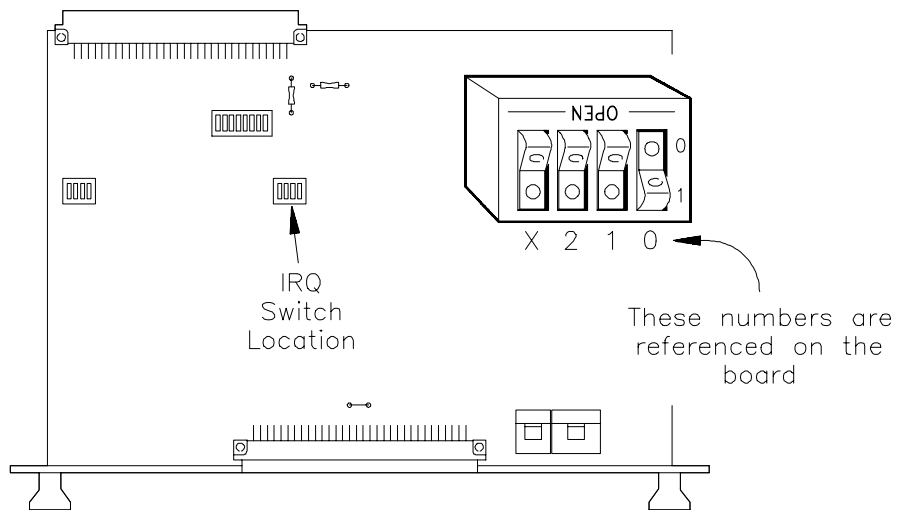

Figure 2-5. Setting the Interrupt Line Number

Setting the Card ID Switch

The multiplexer module can be an HP E1351A, HP E1352A or HP E1353A depending on which terminal module is installed. With a normal connection, the terminal module will automatically configure the module for the appropriate model. However, if you use an extender card which does not connect the middle row of pins, you will have to set the Card ID switch, see Figure 2-6. The ID numbers are:

Model	Value	Configuration
HP E1351A	0	all pins open
HP E1352A	8	pin 3 closed
HP E1353A	2	pin 1 closed

For normal connections, leave the switch at the factory setting which is all pins open.

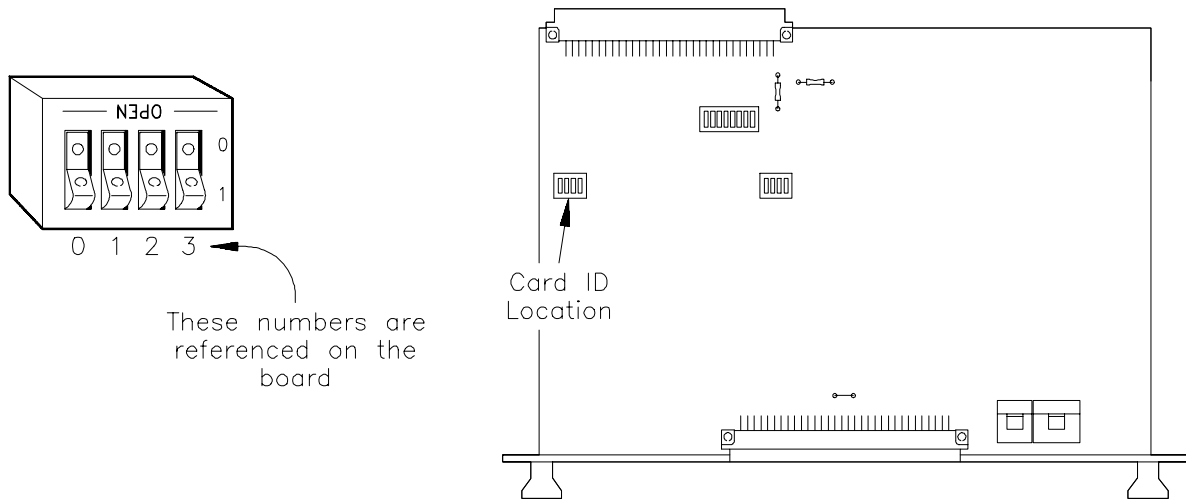

Figure 2-6. Card ID Switch

Removing the Low-to-Guard Isolation Jumper

Isolation jumper JM1 connects the Low (L) and Guard (G) commons together. To minimize errors caused by lead resistance in the low lines, you may want to remove the jumper. Use Figure 2-7 to locate the jumper.

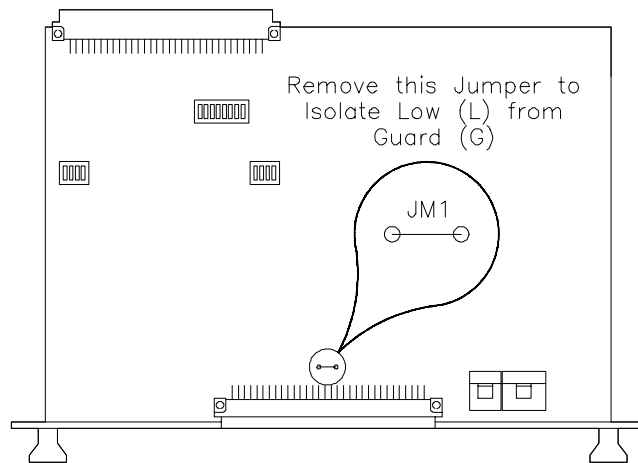

Figure 2-7. Removing the Isolation Jumper

Connecting Field Wiring

Leads for the individual channels are connected through the channel terminals on the terminal modules. Multimeters and signal generators can be connected to the tree terminals on the terminal modules. Figure 2-8 shows the terminal module channel terminals for the 32-Channel Single-Ended FET Multiplexer Module.

Wiring Guidelines

- If possible, use shielded cables with the shields connected to the Guard (G) terminals and to the low connection near the measurement point.
- Be sure the wires make good connections on the screw terminals.

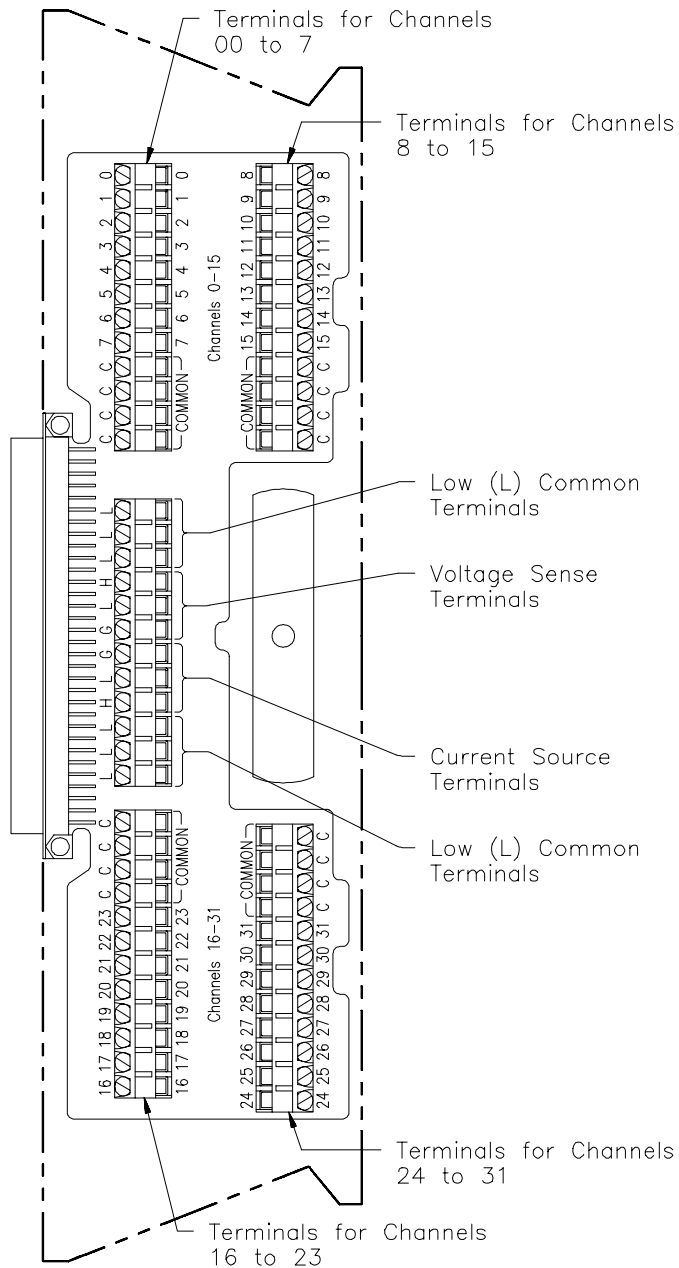
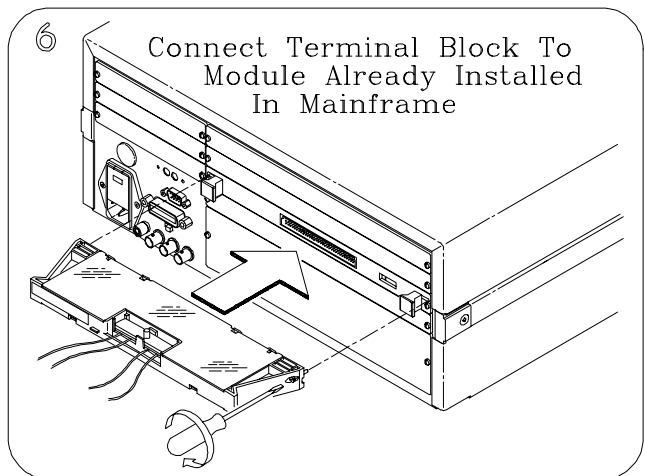
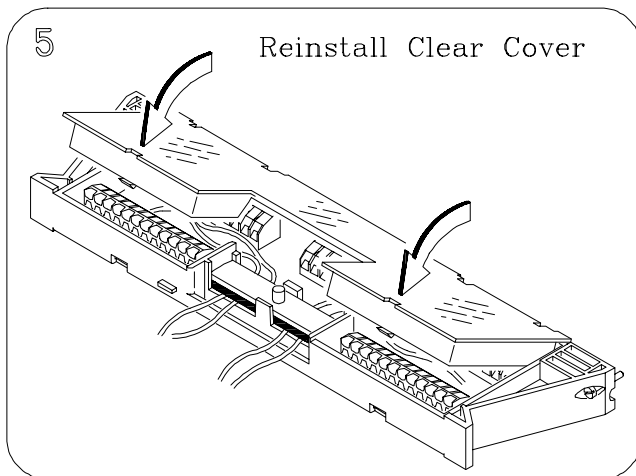
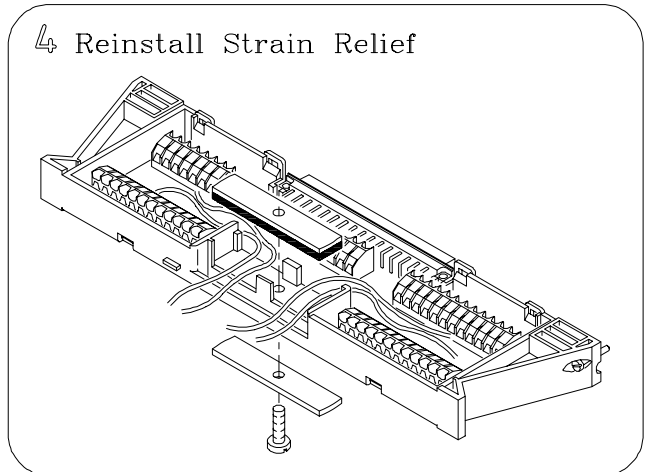
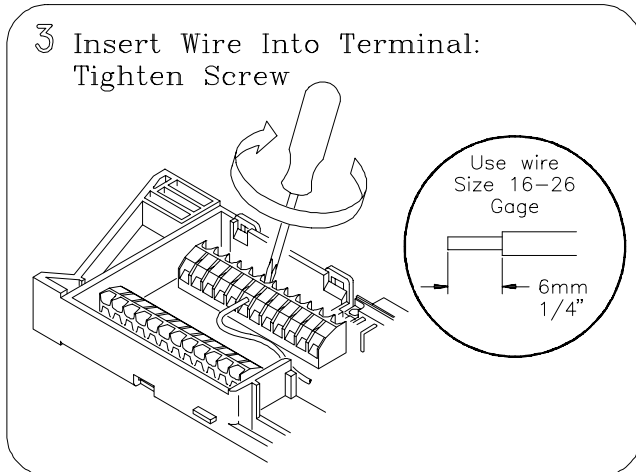
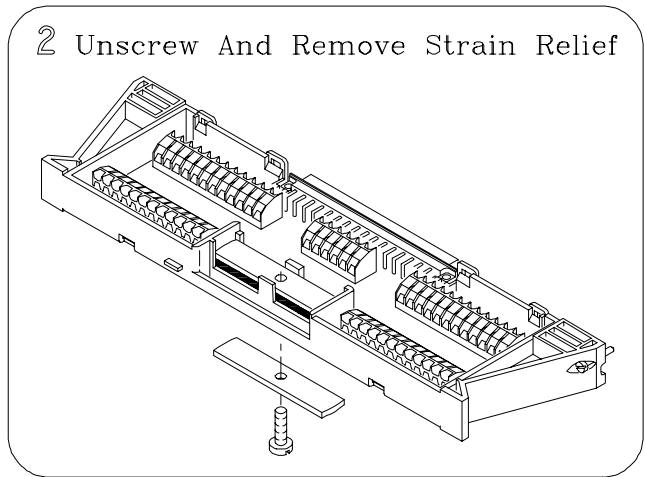
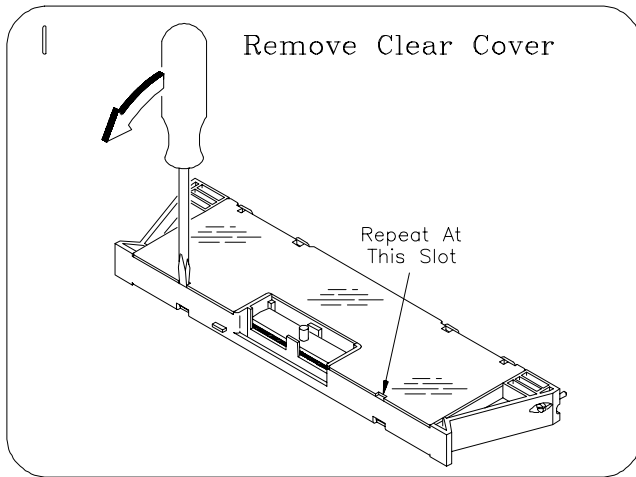

Figure 2-8. Multiplexer Module Terminal Blocks

Wiring a Terminal Module

The following illustrations show how to connect field wiring to the terminal module.



Connecting Multimeters and Signal Generators

Figure 2-9 shows how to connect the analog bus connector and the digital bus handshake cable between multiple multiplexer modules and the HP E1326B Multimeter. Use the cables shipped with the multiplexer modules to make the connections.

Stand-alone multimeters and signal generators can also be connected to the tree terminals. Connections to the tree terminals are made on the terminal module. If the multimeter has "Voltmeter Complete" and "External Trigger" ports that use an open collector TTL pulse, you can use a custom cable to connect it to the digital bus for triggering (see "Digital Bus and Triggering" in Chapter 1).

A.

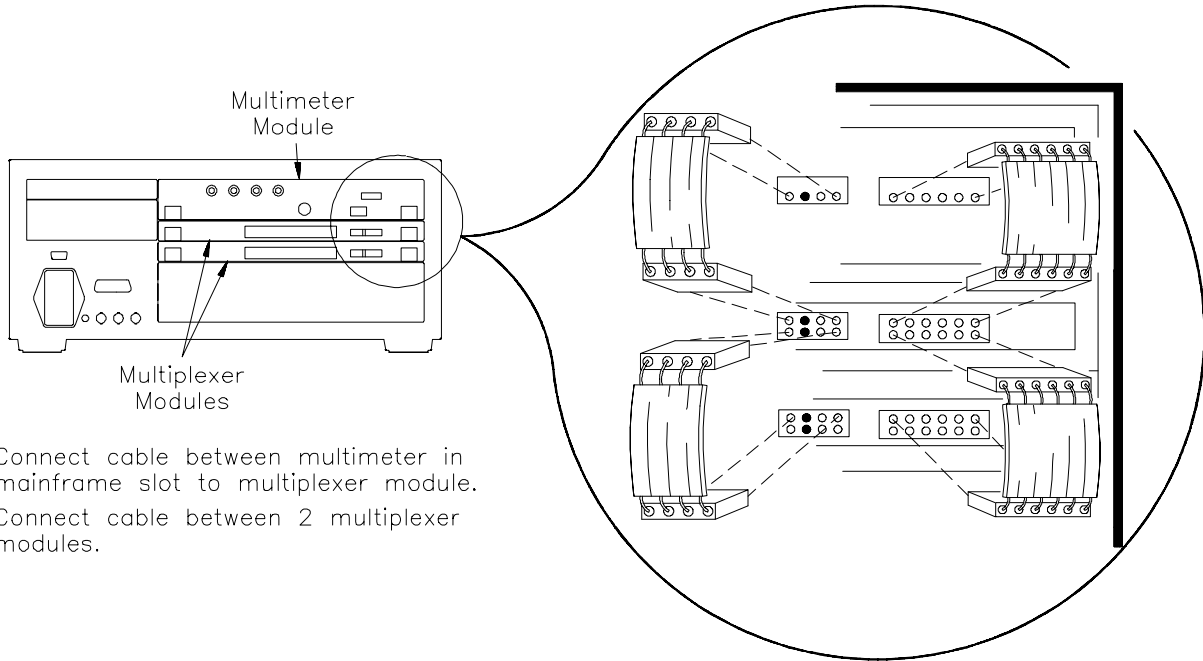

Connect cable between multimeter in mainframe slot to multiplexer module.
Connect cable between 2 multiplexer modules.

B.

Connect cable between multiplexer module to terminals of multimeter inside mainframe.

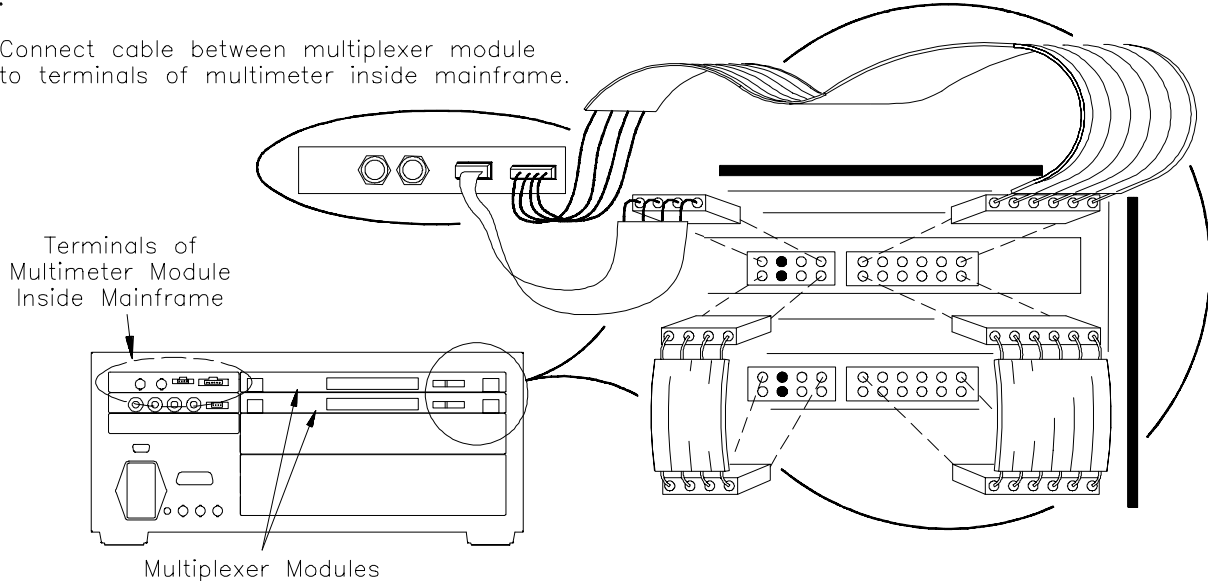

Figure 2-9. Analog Bus and Digital Bus Connections

Connecting User Inputs

The FET multiplexers generally consist of a component module and a terminal module. User inputs are normally connected to the terminal module. Figure 2-10 shows the front panel of the FET multiplexer modules and the module's connector pin-out which mate to the terminal module.

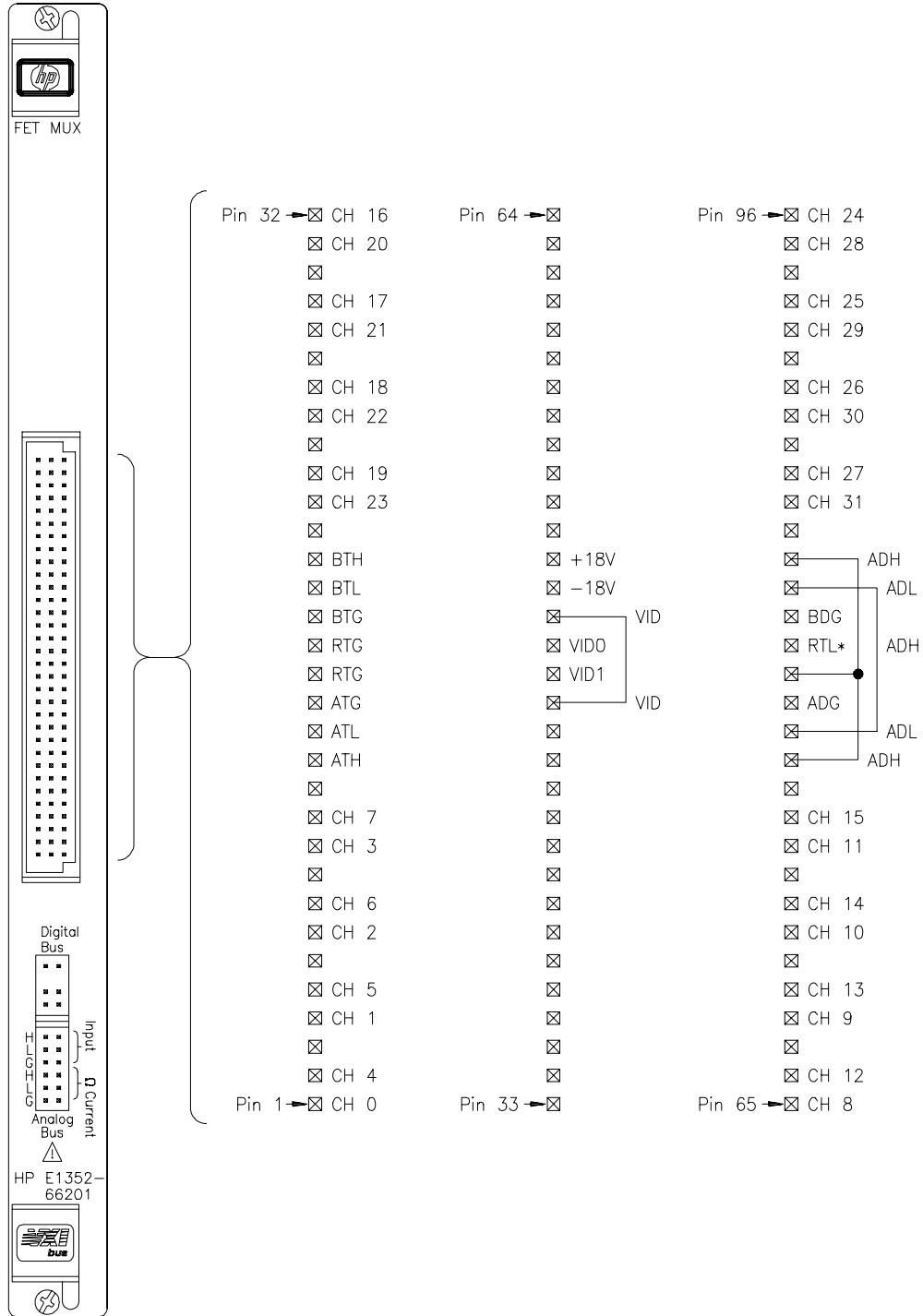

Figure 2-10. FET Multiplexer Front Panel and Pin-out

Chapter 3

Using the HP E1352A FET Multiplexer Module

Using This Chapter

This chapter uses typical examples showing how to use the 32-Channel FET Multiplexer Module. Refer to Chapter 4 for further information. This chapter contains the following sections:

- Selecting Channels Page 27
- Multiplexer Commands Page 28
- Connecting Switchbox Channels to Tree Terminals for Making Measurements Page 29
- Connecting External Current Sources for Making Ohms Measurements Page 31
- Scanning a Range of Switchbox Channels Page 32
- Downloading a Scan List Page 35
- Scanning a Switchbox without a Downloaded Scan List Page 36
- Scanning a Switchbox with a Downloaded Scan List Page 37
- Scanning Voltmeter Configuration with an HP E1326B Page 38

Selecting Channels

Individual channels within a module or multiple-module instrument are selected with the `SCAN <channel_list>` or `OPEN` and `CLOSE <channel_list>` commands. `OPEN` and `CLOSE <channel_list>` immediately opens/closes the specified channel. The `SCAN <channel_list>` command creates a scanning list which can be downloaded into RAM on each module. The `INITiate` command closes the first channel on the scan list, and the selected trigger mode advances the rest of the channels.

The FET Multiplexer Module uses break-before-make logic so that a closed channel is opened before the next channel is closed. Only one channel can be closed at any given time on the FET multiplexer. You can, however, have a channel closed on two different modules in the same instrument.

To address specific channels within a multiplexer module in a switchbox or scanning voltmeter configuration, you must send the appropriate SCPI command string with a specified card number (cc) and channel number (nn). The card number refers to the multiplexer module within a switchbox or scanning voltmeter configuration. The multiplexer module with the lowest logical address in a VXIbus instrument is card number 01, and the next consecutively numbered multiplexer module is card number 02.

If you have more than one switchbox or scanning voltmeter configuration, the card numbering sequence starts at 01 for each configuration. A channel address is, therefore, a four digit number (ccnn). For channel 07 on card 02 the address is 0207. You can delete leading zeros, so 207 is also a valid channel address. The channel address *<channel_list>* is in the form:

- (@ccnn) for a single channel
- (@ccnn,ccnn) for multiple channels
- (@ccnn:ccnn) for sequential channels
- (@ccnn:ccnn,ccnn:ccnn) for groups of sequential channels

The OPEN and CLOSe commands should only be used with the single-channel format and for one unique application of the multiple-channel format. You can close a channel on two different cards in the same instrument (e.g., 102 and 208) at the same time. You cannot close two channels on the same card at the same time (102 and 108). Closing a channel automatically opens all other channels on that card.

CLOS (@102,208,309) *Closes 02 on card 1, 08 on card 2 and 09 on card 3.*

CLOS (@103,204) *Opens 102 and 208, closes 103 and 204; 309 left closed.*

Multiplexer Commands

The following commands are covered in Chapter 3. For a complete list and description of commands see Chapter 5, “HP E1352A Command Reference”.

Command	Description
ARM:COUNT <i><number></i>	Selects number of scanning cycles for a switchbox only. Does not apply to downloaded scan lists.
INIT[:IMM] INIT:CONT 1 0 ON OFF	Closes first channel on scanning list. Enables/disables continuous scanning cycles.
[ROUT:]CLOS <i><channel_list></i> [ROUT:]CLOS? <i><channel_list></i>	Closes specified channels. Queries mainframe for channel closure.
[ROUT:]OPEN <i><channel_list></i>	Opens specified channels.
[ROUT:]SCAN <i><channel_list></i>	Closes all channels in <i><channel_list></i> one at a time; previous channel opens before next channel closes.
[ROUT:]SCAN:MODE RES	Superimposes current source onto channel being measured for resistance measurements.
[ROUT:]SCAN:PORT ABUS	Automatically closes the Tree Isolation Switches.
TRIGger[:IMMEDIATE] TRIGger:SOURce EXT BUS DBUS IMM	Channel advance for TRIGger:SOURce BUS HOLD. Selects trigger source as EXTernal, HP-IB Bus, Digital Bus or IMMEDIATE.
NOTE: The commands with brackets ([]) are implied and are not shown in this chapter.	

Connecting Switchbox Channels to Tree Terminals for Making Measurements

Connect external multimeters to the A tree terminal. The SCAN:PORT ABUS command closes the appropriate FETs on the A and B tree isolation switches, so the channels that are closed are connected to both the analog bus connector and the tree terminals. The A tree terminal is connected to the H, L, and G lines, and the B tree terminal is connected to the I +, I- and G lines. Figure 3-1 shows how to connect multimeters to measure channel 02 and channel 18.

SCAN:PORT ABUS

Enables tree isolation switches.

CLOS (@102)

Close channel 02 on card 01.

CLOS (@118)

Open 02, close 18.

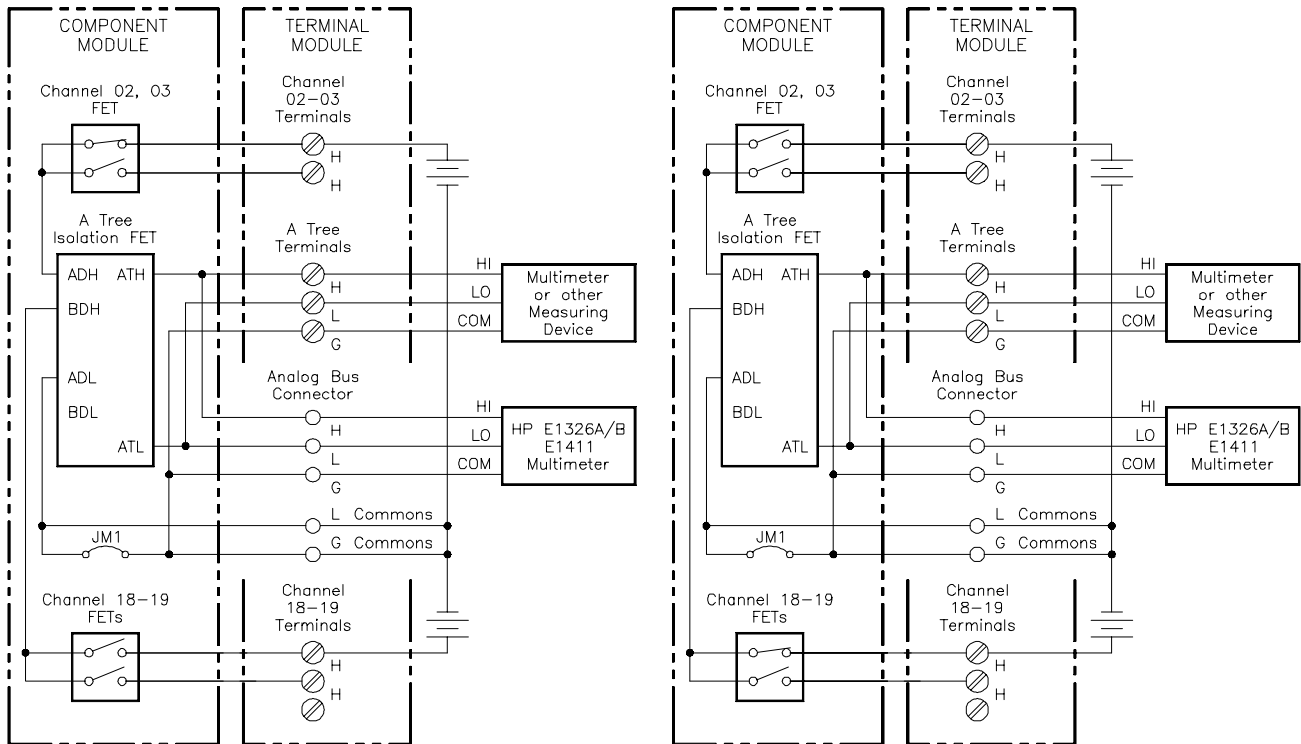

Figure 3-1. Closing Channels 02 and 18 for a Voltage Measurement

Connecting External Current Sources for Making Ohms Measurements

SCAN:MODE RES superimposes a current source on the channel being measured to provide resistance measurements. The current source can be from an external multimeter connected to the B tree terminal or the scanning voltmeter multimeter connected with the analog bus connector. Figure 3-2 shows how to connect current sources to either connector. Execute the following command:

SCAN:MODE RES

Resistance measurements.

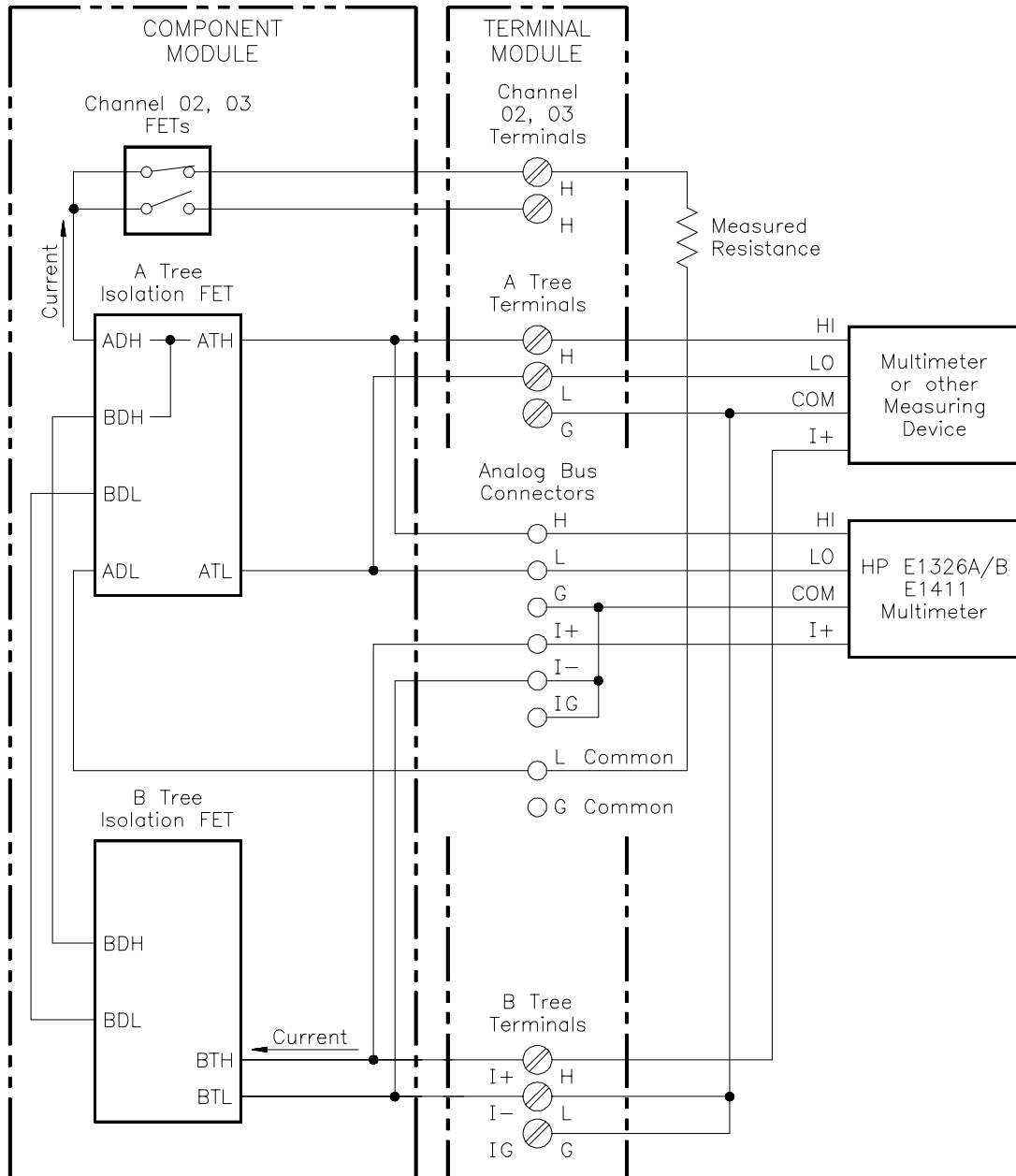

Figure 3-2. Connecting Channel and Current Source for an Ohms Measurement

Scanning a Range of Switchbox Channels

You can scan a range of channels of a switchbox consisting of single or multiple multiplexer modules. Scanning involves sequentially closing each channel on a range of specified channels. The selected TRIGGER mode determines when the channel list will advance. During scanning, the FET which was previously closed opens before the next FET closes.

You can use any of the TRIGGER modes to advance the *channel list*. TRIGGER:SOURCE EXTERNAL requires an external trigger source to be connected to the HP E1300/1301 Mainframe "Event In" port. For computer controlled or HP-IB triggering (TRIGGER or *TRG) use TRIGGER:SOURCE BUS. The OUTPUT ON command enables the Mainframe "Trig Out" port to synchronize multimeters when not in the TRIGGER:SOURCE DBUS | IMM modes.

For the fastest scan rate (up to 100 K switches/sec.) use the TRIGGER:SOURCE DBUS. Use a custom cable (see "Digital Bus and Triggering" in Chapter 1) to connect the multimeter handshake lines (Voltmeter Complete and External Trigger) to the multiplexer digital bus.

Example: Making Voltage Measurements by Scanning

Figures 3-3 and 3-4, and the following commands, show how to make voltage measurements by performing a single scanning cycle of all channels on two multiplexer modules in a single switchbox. In the example, the:

- A Tree Terminals of each terminal module connect to each other and to the multimeter in Figure 3-4. To connect the A Tree Terminals to each other, use either the analog bus cables (shown in Figure 1-2) or wire the terminals together between the terminal modules.
- HP-IB Bus trigger command advances the switchbox channel list.
- HP E1300/E1301 Mainframe's "Trig Out" pulse synchronizes the switchbox with the multimeter.
- Multimeter HP-IB select code is 7 and primary address is 22.
- Switchbox HP-IB select code is 7, the HP-IB primary address is 09, and the HP-IB secondary address is 14.
- Computer is an HP Series 200/300 Computer with HP BASIC using HP-IB.

Enter and execute:

```
10 OUTPUT 722;"TRIG EXT;DC 10"      !Sets multimeter to external
                                     !triggers and to measure dc volts
20 OUTPUT 70914;"OUTP ON"           !Enables "Trig Out" port
30 OUTPUT 70914;"TRIG:SOUR BUS"     !Sets switchbox to receive bus
                                     !triggers
40 OUTPUT 70914;"SCAN:MODE VOLT"!Setup switchbox to measure
                                     !voltage
50 OUTPUT 70914;"SCAN:PORT ABUS"!Closes the appropriate tree
                                     !isolation switches while scanning;
                                     !automatically makes connection to
                                     !the analog bus and tree terminals
```



```

60 OUTPUT 70914;"SCAN (@100:231)"!Selects the channel list.
100 selects the first channel of
module #1; 231 selects the last
channel of module #2

70 OUTPUT 70914;"INIT" !Close first channel to start the
scanning cycle

80 FOR I = 1 TO 64 !Start count loop
90 ENTER 722;A !Enter reading into variable A
100 PRINT A !Print reading in variable A
110 TRIGGER 70914 !Trigger the switchbox to advance
the scan list

120 NEXT I !Increment count
130 END

```

Example: Making 2-Wire Ohms Measurements by Scanning

Use the same setup shown in the second program example in this section. Change the commands in lines 10 and 40 to the following:

```

10 OUTPUT 722;"TRIG EXT:OHM" !Set multimeter to 2-wire ohms
40 OUTPUT 70914;"SCAN:MODE RES"!Closes the appropriate tree
isolation switches

```

This command, when used with SCAN:PORT ABUS and SCAN <channel_list> commands, automatically closes the channels defined in the channel list, along with the appropriate tree isolation switches. The current source is superimposed on the channel being measured.

Example: Making Multiple Scans

The ARM:COUNT <number> command selects multiple scanning cycles for switchboxes with non-downloaded scan lists. It does not apply when the TRIGGER:SOURCE is DBUS or IMMEDIATE.

Add the command before the SCAN <channel_list> in the first program example in this section. When the last channel in a channel list is closed, the pointer is reset back to the beginning of the channel list. The next trigger opens the last channel and closes the first one. This continues for the specified number of cycles.

```

59 OUTPUT 70914;"ARM:COUN 10" !Enables 10 scanning cycles
60 OUTPUT 70914;"SCAN (@100:231)"!Sets scan list
80 FOR I = 1 TO 64

```

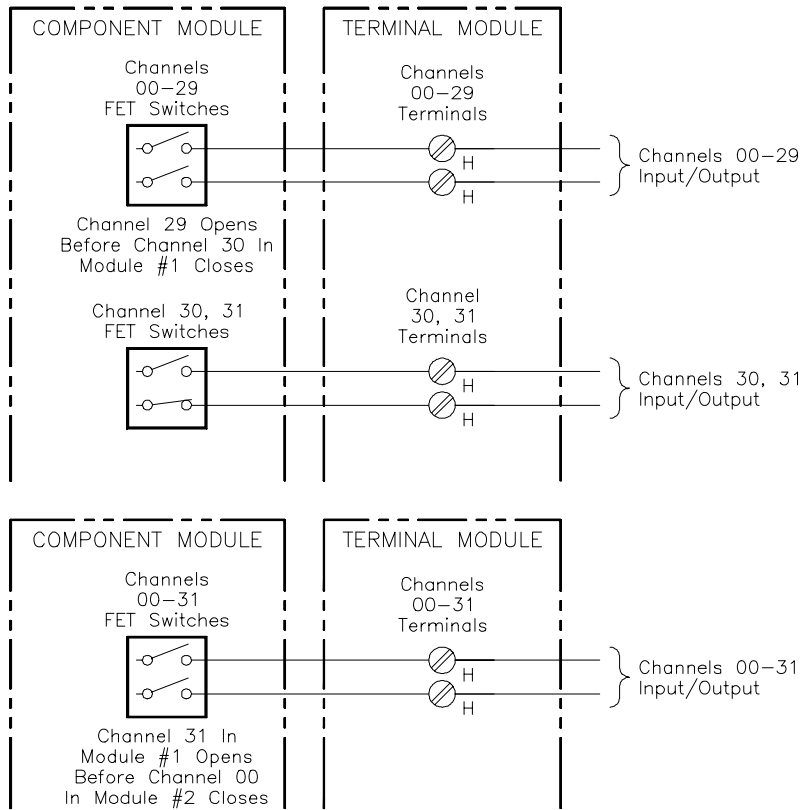

Figure 3-3. Scanning Channels 100 to 231 of a Two-Module Switchbox

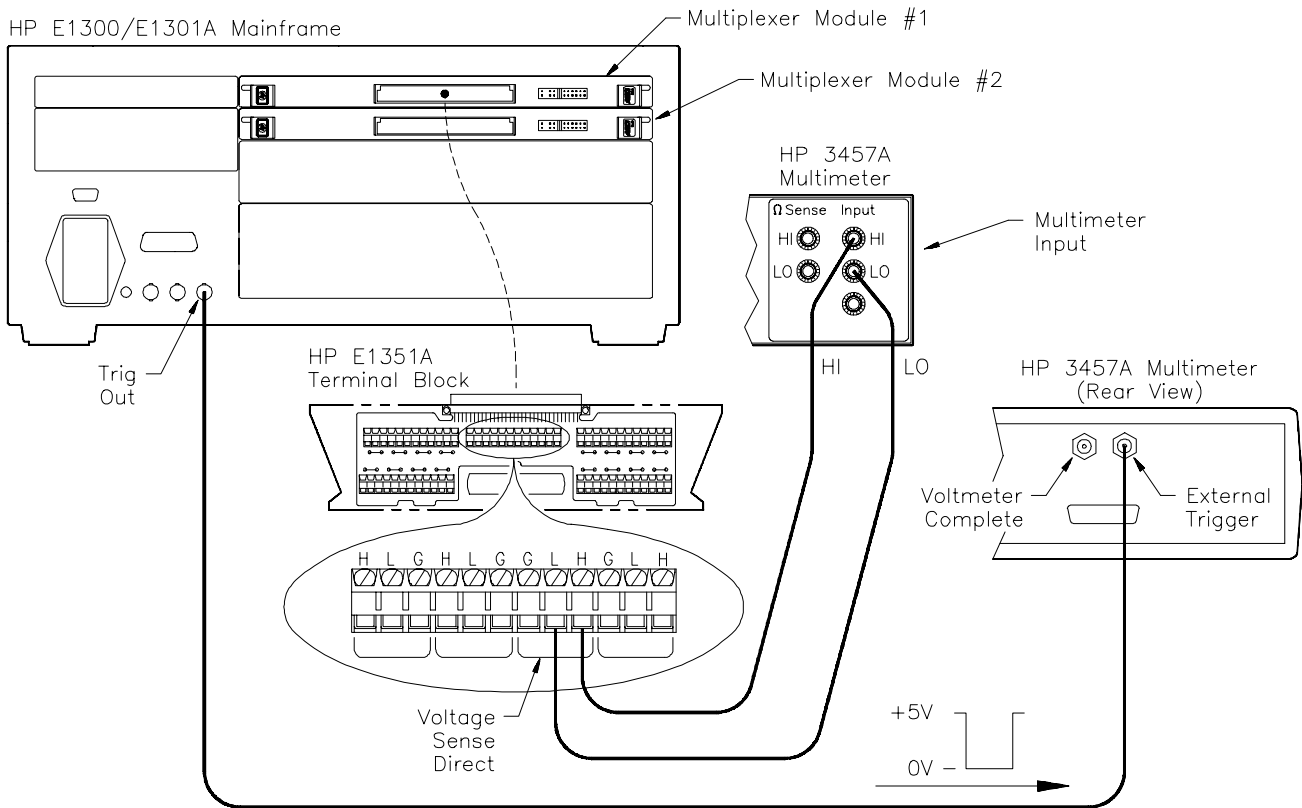

Figure 3-4. Mainframe to Multimeter Connection for Synchronization

Example: Making Continuous Scans

The INITiate:CONTinuous ON command selects continuous scanning cycles (INIT:CONT OFF disables continuous scanning cycles). Add the command to the first program example in this section, as follows:

```
59 OUTPUT 70914;"INIT:CONT ON"      !Enables continuous scanning  
                                     cycles  
60 OUTPUT 70914;"SCAN (@100:231)" !Sets scan list  
80 FOR I = 1 TO X                    !Set the number of measurements  
                                     desired
```

Comments Scanning consists of six steps:

- Connecting the multimeter to the switchbox
- Selecting the SCAN:MODE
- Selecting SCAN:PORT ABUS
- Selecting the TRIGger:SOURce
- Specifying the SCAN <channel_list>
- Starting the scan (INIT or TRIG[:IMMediate])

Downloading a Scan List

The FET Multiplexer Module is primarily designed to be used as a high-speed scanning switchbox or scanning voltmeter. To enable it to make 100,000 connections per second, the SCAN <channel_list> scanning list is downloaded into RAM on the module. This download takes place automatically when you use TRIGger:SOURce DBUS or TRIGger:SOURce IMM. For a multiple-module switchbox, the entire scanning list is downloaded to each module. The channels are advanced to the next channel in the channel list without any direct intervention by the mainframe CPU during the scan.

The scan list is not downloaded for a switchbox or scanning voltmeter that combines both FET and relay multiplexer modules, or for TRIGger:SOURce BUS | EXT | HOLD. The channel closings are controlled by the mainframe CPU. Also, the ARM:COUNT <number> command does not apply to downloaded scan lists. You can use INITiate:CONTinuous ON for continuous scanning with downloaded scan lists.

Scanning a Switchbox without a Downloaded Scan List

This example shows a FET switchbox connected to a multimeter with the analog bus cable. The switchbox and multimeter are separate VXIbus instruments. The multimeter has a secondary address of 03, and the switchbox has a secondary address of 04. The multiplexer is triggered by the *TRG command. OUTPUT ON is enabled, and the multimeter is triggered by the OUTPUT ON trigger to its "External Trigger" port. The following program illustrates the procedures:

```
10 DIM Rdgs(1:32)           !Dimension array to store readings
20 OUTPUT 70903;"*RST;*OPC?" !Clear the multimeter. *OPC?
                               ensures reset is completed before
                               program continues

30 ENTER 70903;A
40 OUTPUT 70903;"*CLS"
50 OUTPUT 70904;"*RST"      !Reset multiplexer
60 OUTPUT 70904;"*CLS"
70 OUTPUT 70903;"CONF:VOLT:DC 58.1" !Configure the multimeter
80 OUTPUT 70903;"TRIG:SOUR EXT" !External trigger source
90 OUTPUT 70903;"TRIG:COUN 32" !Set for 32 triggers
100 OUTPUT 70903;"INIT"     !Initialize multimeter, wait for
                               trigger

110 OUTPUT 70904;"TRIG:SOUR BUS" !Bus Triggers
120 OUTPUT 70904;"SCAN:MODE VOLT" !Configure for voltage
130 OUTPUT 70904;"SCAN:PORT ABUS" !Enables analog bus
140 OUTPUT 70904;"SCAN (@100:131)" !Enter scan list
150 OUTPUT 70904;"OUTP ON"   !Enable mainframe trig out port
160 OUTPUT 70904;"INIT"     !Close first channel
170 FOR I = 1 TO 32         !32 channels
180 OUTPUT 70904;"*TRG"     !Trigger for channel advance
190 WAIT .25                !Allow time for measurement
                               before next advance

200 NEXT I                  !Increment counter
210 OUTPUT 70903;"FETC?"    !Multimeter retrieves readings
                               from mainframe memory when
                               scan completes

220 ENTER 70903;"Rdgs(*)"   !Put readings in array
230 PRINT Rdgs(*)          !Print
240 END
```

Scanning a Switchbox with a Downloaded Scan List

This example shows a FET switchbox connected to multimeter with the analog bus cable and the digital bus cable. The switchbox and multimeter are separate VXIbus instruments. The multimeter has a secondary address of 03, and the switchbox has a secondary address of 04. The triggering is through the digital bus handshake lines, so the scan list is downloaded. The following program illustrates the procedures:

```
10 DIM Rdgs(1:32)           !Dimension array to store readings
20 OUTPUT 70903;"*RST;*OPC?" !Clear the multimeter. *OPC?
                               ensures reset is completed before
                               program continues

30 ENTER 70903;A
40 OUTPUT 70903;"*CLS"
50 OUTPUT 70904;"*RST"      !Reset multiplexer
60 OUTPUT 70904;"*CLS"
70 OUTPUT 70903;"CONF:VOLT:DC 58.1" !Configure the multimeter
80 OUTPUT 70903;"TRIG:SOUR EXT" !External trigger source
90 OUTPUT 70903;"TRIG:COUN 32" !Set for 32 Triggers
100 OUTPUT 70903;"INIT"     !Initialize multimeter, wait for
                               trigger
110 OUTPUT 70904;"STAT:OPER:ENAB 256"
                               !Enable Operation Complete bit
120 OUTPUT 70904;"TRIG:SOUR DBUS" !Digital Bus Triggers
130 OUTPUT 70904;"SCAN:MODE VOLT" !Configure for voltage
140 OUTPUT 70904;"SCAN:PORT ABUS" !Enables analog bus
150 OUTPUT 70904;"SETT:TIME MAX,(@100)"
                               !Delay for signal to settle before
                               multiplexer enables channel closed
                               pulse
160 OUTPUT 70904;"SCAN (@100:131)" !Enter scan list
170 OUTPUT 70904;"INIT"     !Close first channel
180 OUTPUT 70903;"FETCh?"   !Multimeter retrieves readings
                               from mainframe memory when
                               scan completes
190 ENTER 70903;"Rdgs(*)"   !Put readings in array
200 PRINT Rdgs(*)           !Print
210 END
```

Scanning Voltmeter Configuration with an HP E1326B

This example shows an HP E1326B Multimeter and an HP E1352A Multiplexer combined into a single VXIbus instrument, a scanning voltmeter. The secondary address for the scanning voltmeter is 03. Both the analog bus connector and the digital bus connector are used. Once the scanning starts, there is no intervention from the mainframe CPU. The scan list is in RAM on the multiplexer, and the two handshake lines on the digital bus control the triggering.

The following program illustrates the procedures:

```
10 DIM Rdgs(1:32)                !Dimension array to store readings
20 OUTPUT 70903;"*RST;*OPC?"     !Clear the multimeter. *OPC?
                                   !ensures reset is completed before
                                   !program continues

30 OUTPUT 70903;"*CLS"
40 OUTPUT 70903;"CONF:VOLT:DC 58.1,(@100:131)"
                                   !Configures multimeter; also
                                   !automatically configures
                                   !multiplexer for SCAN:MODE,
                                   !SCAN:PORT and TRIG:SOUR

50 OUTPUT 70903;"INIT"          !Close first channel, start scan
60 OUTPUT 70903;"FETC?"        !Retrieve readings from mainframe
70 ENTER 70903;"Rdgs(*)"
80 PRINT Rdgs(*)
90 END
```

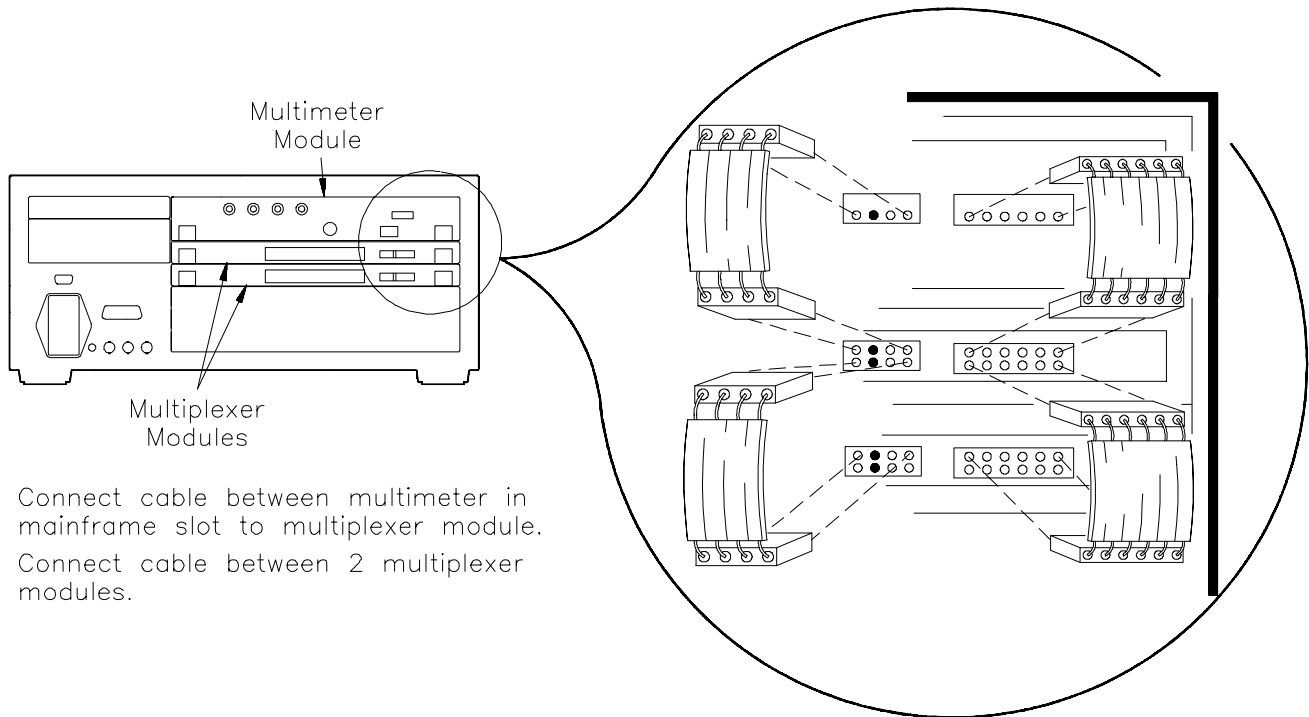

Figure 3-5. Connecting the Analog Bus and Digital Bus Cables

Chapter 4

Understanding the HP E1352A FET Multiplexer

Using This Chapter

This chapter explains scanning techniques for the 32-Channel Single-Ended FET Multiplexer Module. This chapter contains the following sections:

- Commands for Scanning Switchbox Channels Page 39
- Using Scanning Trigger Sources Page 39
- Using the Scan Complete Bit. Page 46

Commands for Scanning Switchbox Channels

Scanning multiplexer channels consists of closing a set of channels, one at a time. The multiplexer has single, multiple, or continuous scanning modes. See Figure 4-1 for the different commands used in scanning.

Using Scanning Trigger Sources

The TRIGger:SOURce command specifies the source to advance the channel list. Figure 4-2 shows the different trigger sources. TRIG:SOUR DBUS uses the digital bus handshake lines. You can use the TRIG[:IMM] command to immediately advance the channel list while in the TRIG:SOUR BUS or TRIG:SOUR HOLD mode. (Note that TRIG:SOUR IMM is not the same as TRIG[:IMM].) To enable the HP E1300/E1301 Mainframe "Trig Out" port, use the OUTP ON command. The "Event In" mainframe trigger source is reserved with the TRIG:SOUR EXT command. "Trig Out" and "Event In" are mainframe resources, and can only be allocated to one instrument at a time.

Scanning with External Instruments

The examples in this chapter show different ways to scan channels of a switchbox in an HP E1300/E1301 Mainframe. The operation is similar to other HP VXIbus mainframes with HP command modules that have "Trig Out" and "Event In" ports. The computer used in the examples is an HP Series 200/300 used with HP BASIC as the program language. The computer interfaces with the mainframe over HP-IB. Assumed is an:

- HP-IB select code of 7
- HP-IB primary address of 09 for the HP E1300/E1301 Mainframe
- HP-IB primary address of 22 for the HP 3457A Multimeter
- HP-IB secondary address of 14 for the multiplexer module

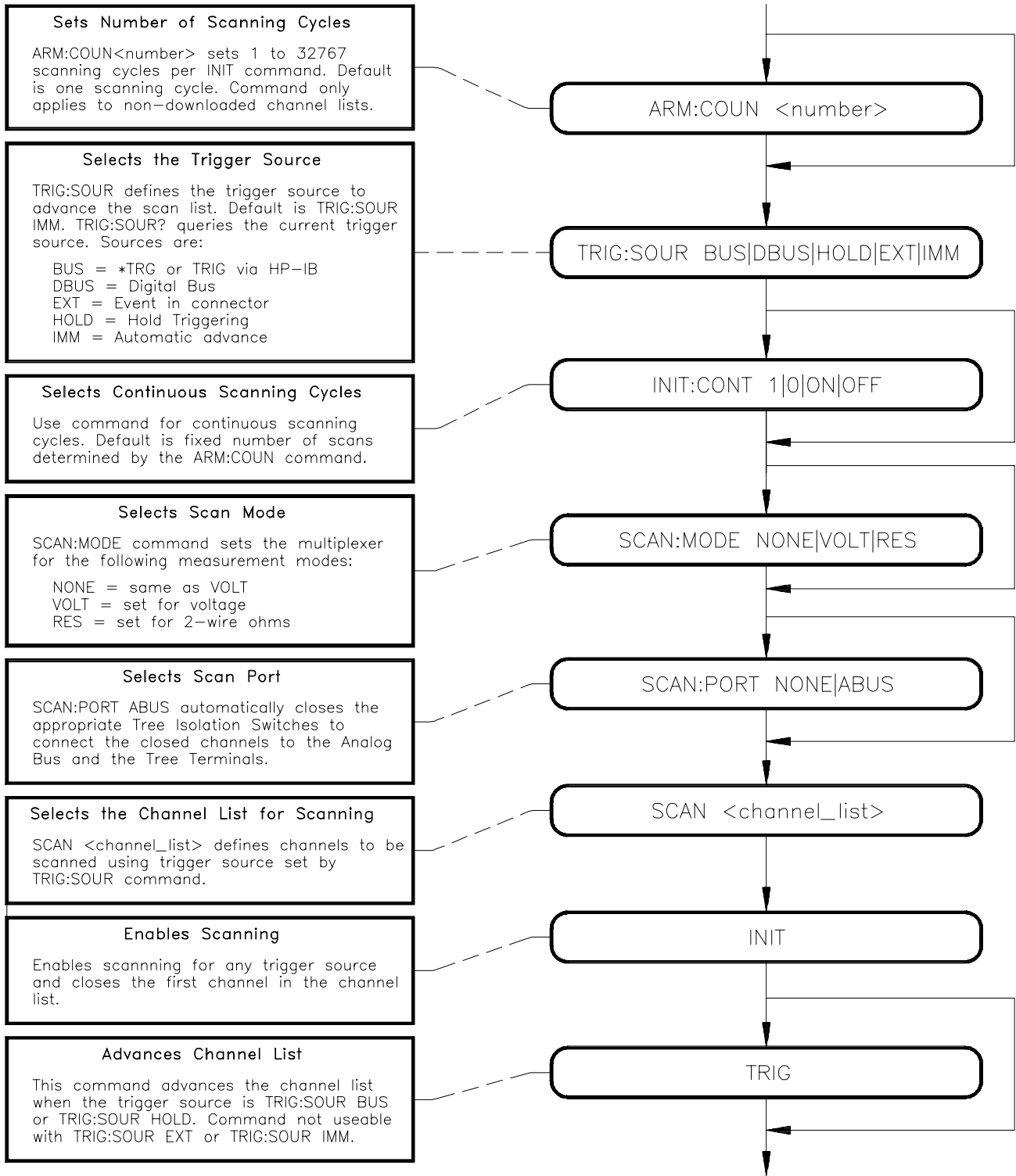

Figure 4-1. Scanning Commands

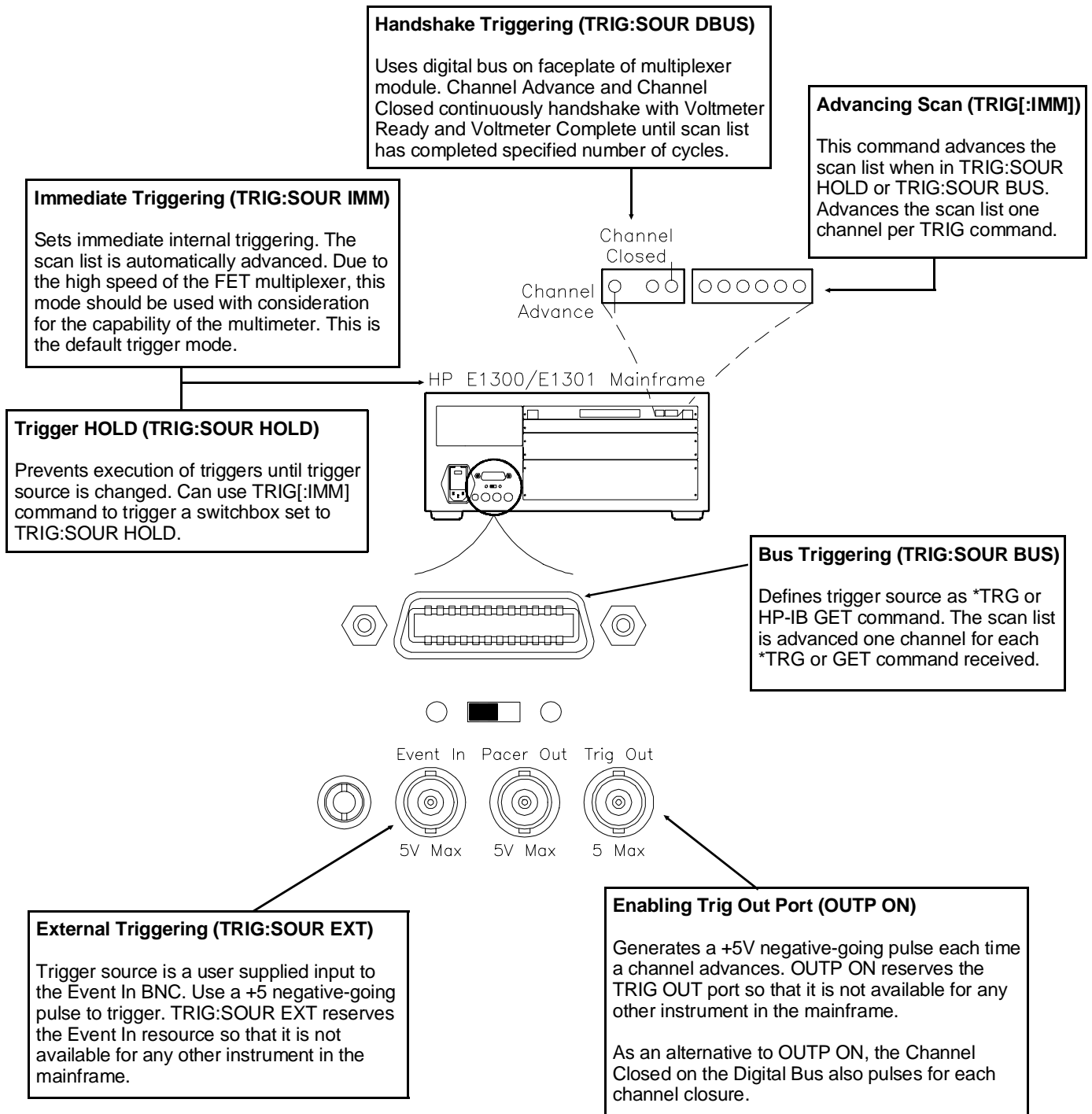

Figure 4-2. Trigger Sources

Example: Scanning with External Instruments

This example uses the mainframe "Trig Out" port to synchronize the multiplexers to an HP 3457A Digital Multimeter. See the following figure for typical connections. For this example, use the trigger output pulse of the mainframe "Trig Out" port to trigger the multimeter from its "External Trigger" port.

The sequence of operation is:

1. INIT (line 70) closes channel number 100.
2. The channel closure causes a trigger output from the "Trig Out" port.
3. The trigger causes the multimeter to make a measurement.
4. Measurement result is sent to the computer (lines 80 to 100).
5. TRIGGER command (line 110) advances the channel list to the next channel.
6. Steps 2-5 are repeated for channels 101 through 131.

```

10  OUTPUT 722;"TRIG EXT;DCV"      !Sets multimeter to external trigger
                                     and to measure dc volts
20  OUTPUT 70914;"OUTP ON"         !Enables "Trig Out" port
30  OUTPUT 70914;"TRIG:SOUR BUS"  !Sets switchbox to receive bus
                                     triggers
40  OUTPUT 70914;"SCAN:MODE VOLT"!Sets switchbox to measure
                                     voltage
50  OUTPUT 70914;"SCAN:PORT ABUS"!Closes the tree isolation switches
60  OUTPUT 70914;"SCAN (@100:131)!Selects the channel list for
                                     scanning
70  OUTPUT 70914;"INIT"           !Starts scanning cycle
80  FOR I = 1 TO 32                !Start count loop
90  ENTER 722;A                    !Enter reading into variable A
100 PRINT A                         !Print reading in variable A
110 TRIGGER 70914                  !Trigger the switchbox to advance
                                     the channel list
120 NEXT I                          !Increment count
130 END

```

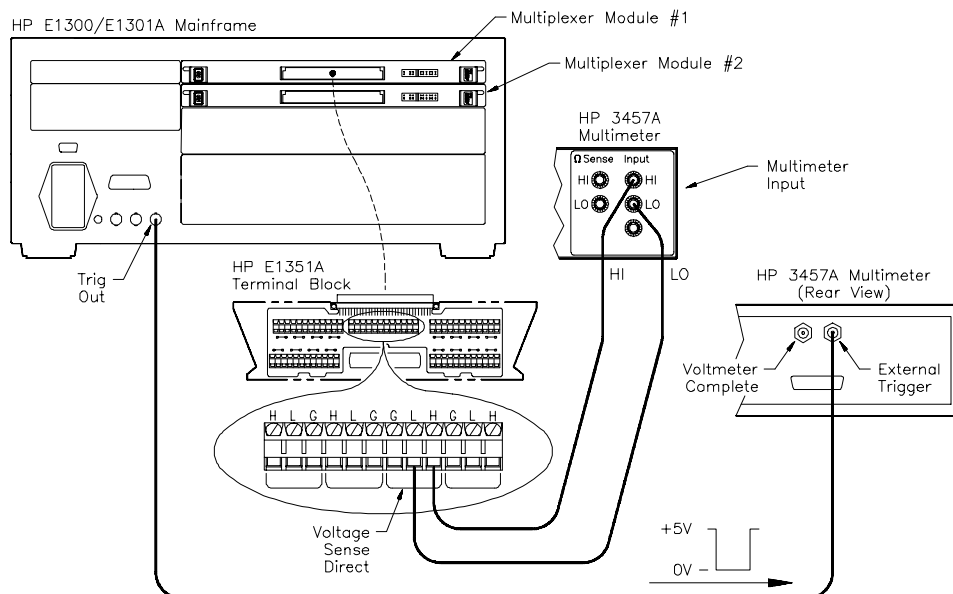

Example: Scanning Using "Trig Out" and "Event In" Ports

This example uses the mainframe "Trig Out" and "Event In" ports to synchronize the multiplexers to an HP 3457A Digital Multimeter. See the following figure for typical connections.

For this example, use the trigger output pulse of the mainframe "Trig Out" port to trigger the multimeter from its "External Trigger" port. Note that the pulse output from the multimeter's "Voltmeter Complete" port triggers the switchbox to advance the channel list. Use the multimeter's reading storage capability to store readings.

The sequence of operation is:

1. INIT (line 50) closes channel number 100.
2. The channel closure causes a trigger output from the "Trig Out" port.
3. The trigger causes the multimeter to make a measurement.
4. Measurement result is stored into multimeter memory.
5. Trigger is output from multimeter's "Voltmeter Complete" port.
6. Trigger to "Event In" port advances the channel list to the next channel.
7. Steps 2-6 are repeated for channels 101 through 131.

- ```

10 OUTPUT 722;"TRIG EXT:DCV:MEM FIFO"!Sets multimeter to external
 trigger to measure dc volts and store readings
20 OUTPUT 70914;"OUTP ON" !Enables "Trig Out" port
30 OUTPUT 70914;"TRIG:SOUR EXT" !Sets switchbox to receive external
 triggers
40 OUTPUT 70914;"SCAN (@100:131)"!Selects the channel list (channels
 100 to 131)
50 OUTPUT 70914;"INIT" !Starts scanning cycle
60 END

```

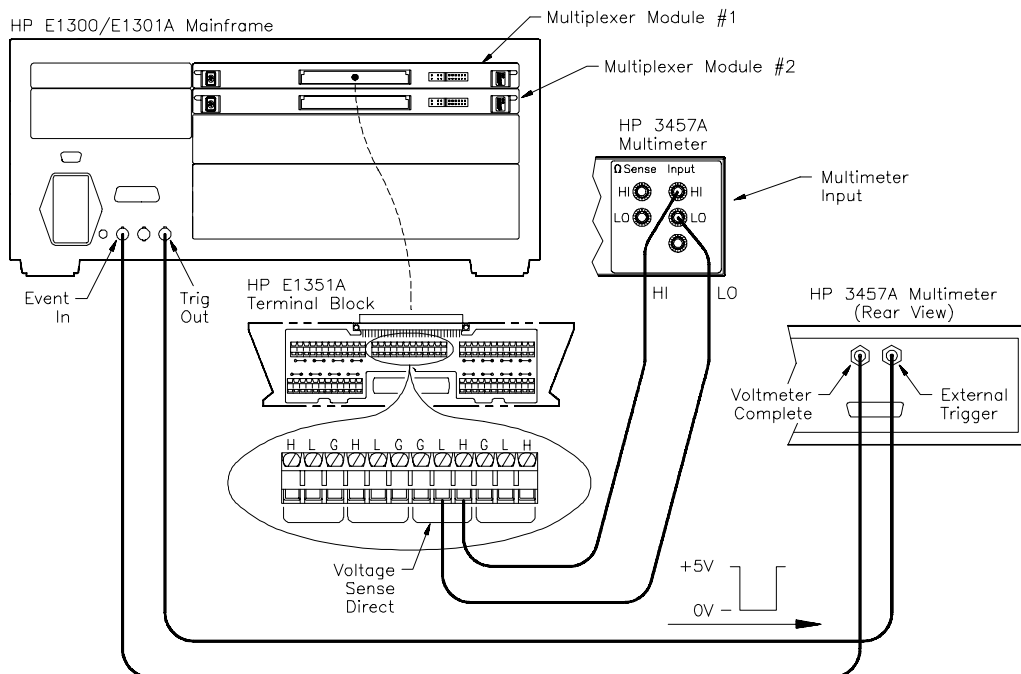

## Example: Scanning Using Stand-Alone Multimeter and Digital Bus Triggering

This example is similar to the previous one except that the multimeter's "External Trigger" and "Voltmeter Complete" ports are connected to the "Channel Closed" and "Channel Advance" on the FET Multiplexer digital bus. See Chapter 1 for information on making custom digital bus cables. Once the scanning procedure has been initiated (INIT), the channel closure is advanced by the handshake lines. The INIT command closes the first channel, and when the channel is closed, the "Channel Closed" pulses. This is connected to the "External Trigger" on the multimeter, which triggers a reading. When the reading is complete, the "Voltmeter Complete" triggers, which pulses the "Channel Advance". This procedure continues until the end of the scan list.

The sequence of operation is:

1. TRIG:SOUR DBUS selects digital bus triggering.
  2. INIT (line 50) closes channel number 100.
  3. The channel closure causes a trigger output from the "Channel Closed" port.
  4. The trigger causes the multimeter to make a measurement.
  5. Measurement result is stored into multimeter memory.
  6. Trigger is output from multimeter's "Voltmeter Complete" port.
  7. Trigger to "Advance Channel" port advances the channel list to the next channel.
  8. Steps 3-7 are repeated for channels 101 through 131.
- 
- 10 OUTPUT 722;"TRIG EXT;DCV;MEM FIFO"!Sets multimeter to external trigger to measure dc volts and store readings
  - 20 OUTPUT 7094;"SCAN:PORT ABUS"!Routes channels to analog bus connector and A tree terminal
  - 30 OUTPUT 7094;"TRIG:SOUR DBUS"!Sets switchbox to receive external triggers
  - 40 OUTPUT 7094;"SCAN (@100:131)!Selects the channel list (channels 100 to 131)
  - 50 OUTPUT 7094;"INIT" !Starts scanning cycle
  - 60 END

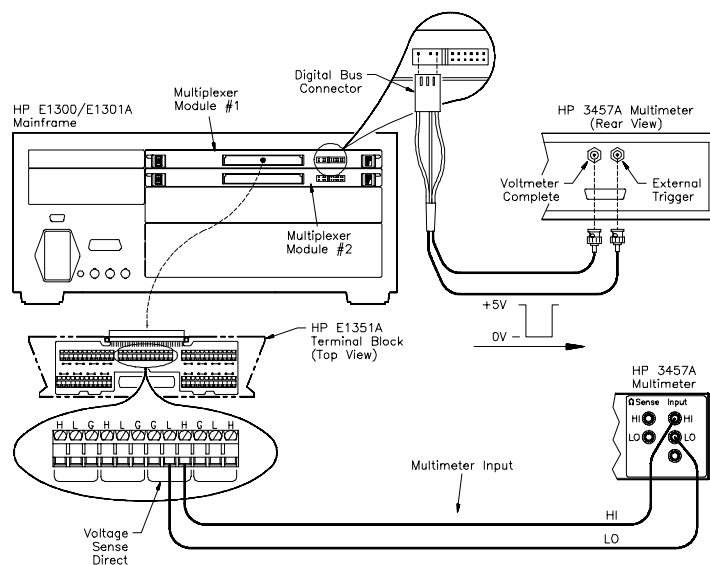

## Example: Scanning Using Scanning Voltmeter Configuration and Digital Bus Triggering

In this example the HP E1326B Multimeter is combined with a FET multiplexer to form a scanning voltmeter VXIbus instrument. The multimeter is address 24, and the multiplexer is address 25, so the instrument secondary address is 03. The analog bus connector and the digital bus connector are connected between the modules. The TRIG:SOURce is set for DBUS. This configuration provides the fastest speed. Consult the *HP E1326B/E1411B Multimeter User's Manual* for further information on multimeter settings. Note that the ARM:COUNT command does not apply to downloaded scan lists.

The sequence of operation is:

1. The multimeter automatically configures the multiplexer for SCAN:MODE, SCAN:PORT and TRIGger:SOURce DBUS.
2. INIT closes first channel.
3. The channel closure causes a trigger output from the "Channel Closed" port.
4. The trigger causes the multimeter to make a measurement.
5. Measurement result is stored into multimeter memory.
6. Trigger is output from multimeter's "Voltmeter Complete" port.
7. Trigger to "Advance Channel" port advances the channel list to the next channel.
8. Steps 3-7 are repeated for channels 101 through 131.

```

10 DIM Rdgs(1:32) !Dimension array for readings
20 OUTPUT 70903;"*RST" !Reset scanning voltmeter
30 OUTPUT 70903;"CONF:VOLT DC (@100:131)"
 !Sets multimeter to measure dc volts
40 OUTPUT 70903;"INIT" !Starts scanning cycle
50 OUTPUT 70903;"FETC?" !Get the readings
60 ENTER 70903;Rdgs(*) !Place values in array
70 PRINT Rdgs(*) !Print values
80 END

```

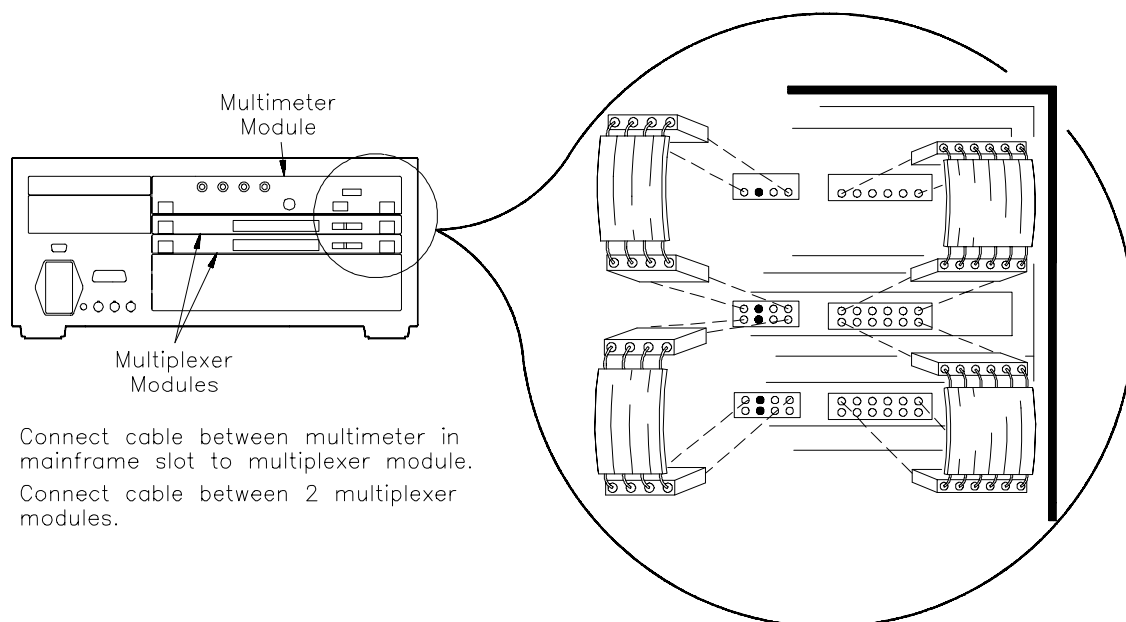

# Using the Scan Complete Bit

You can use the Scan Complete Bit (bit 8) in the SCPI Operation Status Register to determine when a scanning cycle completes (no other bits in the register apply to the switchbox). Bit 8 has a decimal value of 256 and you can read it directly with the STAT:OPER? command (refer to the STATus:OPERation[:EVENT]? command in Chapter 5 for an example). Note that this is not the same register as the multiplexer Status/Control Register.

When enabled by the STAT:OPER:ENAB 256 command, the Scan Complete Bit will be reported as bit 7 of the Status Register. Use the HP-IB Serial Poll or the IEEE 488.2 Common Command \*STB? to read the Status Register. When bit 7 of the status Register is enabled by the \*SRE 128 Common Command to assert an HP-IB Service Request (SRQ), you can interrupt the controller when the Scan Complete Bit is set, after a scanning cycle completes. This allows the controller to do other operations while the scanning cycle is in progress.

The following example monitors bit 7 in the Status Register to determine when the scanning cycle completes. The computer used in the example is an HP Series 200/300 used with HP BASIC as the program language. The computer interfaces with the mainframe over HP-IB. The HP-IB select code is 7, the HP-IB primary address is 09, and the HP-IB secondary address is 14.

## Example: Scan Complete Monitor

```
10 OUTPUT 70914;"*CLS" !Clear all switchbox status
 structure
20 OUTPUT 70914;"STAT:OPER:ENAB 256"
 !Enable Scan Complete Bit to set
 bit 7 in Status Register
30 OUTPUT 70914;"*SRE 128" !Enable bit 7 of Status Register to
 assert SRQ
40 OUTPUT 70914;"TRIG:SOUR EXT" !Set to external trigger mode
50 OUTPUT 70914;"SCAN (@100:131)" !Select channels to be scanned
60 OUTPUT 70914;"INIT" !Start scanning cycle
70 WHILE NOT BIT (SPOLL(70914),7) !Waiting for scan complete
80 PRINT "DO OTHER OPERATION HERE"
 !Enter program lines for computer
 to do other operations

90 END WHILE
100 PRINT "INTERRUPT GENERATED" !Program goes to this line after
 interrupt is generated by a
 completed scanning cycle

110 END
```

# Chapter 5 HP E1352A FET Multiplexer Command Reference

---

## Using This Chapter

This chapter describes Standard Commands for Programmable Instruments (SCPI) commands and summarizes IEEE 488.2 Common (\*) Commands applicable to the HP E1352A 32-Channel Single-Ended FET Multiplexer Module. This chapter contains the following sections.

- Command Types . . . . . Page 47
- SCPI Command Reference . . . . . Page 49
- IEEE 488.2 Common Commands . . . . . Page 70
- Command Quick Reference . . . . . Page 71

## Command Types

Commands are separated into two types: IEEE 488.2 Common Commands and SCPI Commands.

### Common Command Format

The IEEE 488.2 standard defines the Common Commands that perform functions like reset, self-test, status byte query, etc. Common Commands are three or four characters in length, always begin with the asterisk character (\*), and may include one or more parameters. The command keyword is separated from the first parameter by a space character. Some examples of Common Commands are shown below:

\*RST      \*ESR 32      \*STB?

### SCPI Command Format

The SCPI commands perform functions like closing switches, making measurements, querying instrument states or retrieving data. A subsystem command structure is a hierarchical structure that usually consists of a top-level (or root) command, one or more lower level commands, and their parameters. The following example shows part of a typical subsystem:

```
[ROUTE:]
 CLOSe <channel_list>
 SCAN <channel_list>
 :MODE VOLT
```

[ROUTE:] is the root command, CLOSe and SCAN are second-level commands with parameters, and MODE is a third-level command with the parameter VOLT.

## Command Separator

A colon (:) always separates one command from the next lower level command as shown below:

```
ROUTe:SCAN:MODE VOLT
```

Colons separate the root command from the second-level command (ROUTe:SCAN) and the second-level from the third-level (SCAN:MODE VOLT). The parameters of a command are separated from the command by a blank space.

## Abbreviated Commands

The command syntax shows most commands as a mixture of upper and lower case letters. The upper case letters indicate the abbreviated spelling for the command. For shorter program lines, send the abbreviated form. For better program readability, you may send the entire command. The instrument will accept either the abbreviated form or the entire command.

For example, if the command syntax shows MEASure, then MEAS and MEASURE are both acceptable forms. Other forms of MEASure, such as MEASU or MEASUR will generate an error. You may use upper or lower case letters. Therefore, MEASURE, measure, and MeAsUrE are all acceptable.

Command keywords can be entered in their full form, as shown above, or can be entered in their short form. In this manual, the entry required in short form commands is always capitalized. The short form is generally used for examples in this manual.

## Implied Commands

Implied commands are those which appear in square brackets ( [ ] ) in the command syntax. (Note that the brackets are not part of the command and are not sent to the instrument.) Suppose you send a second level command but do not send the preceding implied command. In this case, the instrument assumes you intend to use the implied command and it responds as if you had sent it. Examine this excerpt from the [ROUTe:] subsystem shown below:

```
[ROUTe:]
 SCAN <channel_list>
 :MODE <mode>
 :MODE?
 :PORT <port>
```

Both the root command [ROUTe:] is an implied command. To set the instrument's scanning list, you can send either of the following command statements:

```
ROUTe:SCAN (@100:131) or SCAN (@100:131)
```

---

### Note

You must include a space between the keywords and any parameters.

---



**Parameters** **Parameter Types.** The following table contains explanations and examples of parameter types you might see later in this chapter.

| Parameter Type | Explanations and Examples                                                                                                                                                                                                                                                                                                                                |
|----------------|----------------------------------------------------------------------------------------------------------------------------------------------------------------------------------------------------------------------------------------------------------------------------------------------------------------------------------------------------------|
| Numeric        | Accepts all commonly used decimal representations of numbers including optional signs, decimal points, and scientific notation.<br><br>123, 123E2, -123, -1.23E2, .123, 1.23E-2, 1.23000E-01. Special cases include MIN, MAX, and DEF. MIN selects minimum value available, MAX selects maximum value available, and DEF selects default or reset value. |
| Boolean        | Represents a single binary condition that is either true or false.<br><br>1 or ON; 0 or OFF.                                                                                                                                                                                                                                                             |
| Discrete       | Selects from a finite number of values. These parameters use mnemonics to represent each valid setting.<br><br>An example is the TRIGger:SOURce <source> command where <i>source</i> can be BUS, DBUS, EXT, HOLD, or IMM.                                                                                                                                |

**Optional Parameters.** Parameters shown within square brackets ( [ ] ) are optional parameters. (Note that the brackets are not part of the command and are not sent to the instrument.) If you do not specify a value for an optional parameter, the instrument chooses a default value. For example, consider the ARM:COUNT? [<MIN | MAX>] command. If you send the command without specifying a parameter, the present ARM:COUNT value is returned. If you send the MIN parameter, the command returns the minimum count available. If you send the MAX parameter, the command returns the maximum count available. Be sure to place a space between the command and the parameter.

## Linking Commands

### Linking IEEE 488.2 Common Commands with SCPI Commands.

Use a semicolon between the commands. For example:

```
*RST;OUTP ON or TRIG:SOUR BUS;*TRG
```

**Linking Multiple SCPI Commands.** Use both a semicolon and a colon between the commands. For example:

```
ARM:COUN 1;;TRIG:SOUR EXT
```

## SCPI Command Reference

This section describes the Standard Commands for Programmable Instruments (SCPI) commands for the multiplexer modules. Commands are listed alphabetically by subsystem and also within each subsystem.

# ABORt

The ABORt subsystem stops a scan in progress when the scan is enabled via the interface, and the trigger modes are TRIGger:SOURce BUS or TRIGger:SOURce HOLD.

## Subsystem Syntax

ABORt

## Comments

- **ABORt Operation.** Resets the trigger system and places triggers in idle. The scan is stopped without resetting the scan conditions. The scan conditions stay in the current configuration.
- **Stopping Scans Enabled from Interface.** When a scan is enabled from the interface, use an interface CLEAR command or the HP E1301 front panel "Reset Instr" or "Clear Instr" key to stop the scan.

When the scan is enabled from the interface and the trigger source is TRIGger:SOURce BUS or TRIGger:SOURce HOLD, use ABORt or the HP E1301 front panel "Reset Instr " or "Clear Instr "keys to stop the scan.

- **Stopping Scans Enabled from Front Panel.** When a scan is enabled from the HP E1301 front panel execute \*RST over the interface or use the front panel "Reset Instr " or "Clear Instr" keys to stop the scan.
- **Related Commands.** ARM, INITiate:CONTInuous, [ROUTE:]SCAN, TRIGger

## Example Stopping a Scan with ABORt

|                 |                                |
|-----------------|--------------------------------|
| TRIG:SOUR BUS   | <i>Bus is trigger source</i>   |
| INIT:CONT ON    | <i>Set continuous scanning</i> |
| SCAN (@100:131) | <i>Sets channel list</i>       |
| INIT            | <i>Starts scanning cycle</i>   |
| ABOR            | <i>Aborts scan in progress</i> |

# ARM

The ARM subsystem selects the number of scanning cycles (1 - 32767) for each INIT command. This command does not apply to downloaded scan lists. For downloaded scan lists, use INIT:CONT ON for multiple scans.

## Subsystem Syntax

ARM  
:COUNT <number> MIN | MAX  
:COUNT? [MIN | MAX]

**:COUNT** **ARM:COUNT <number> MIN | MAX** allows scanning cycles to occur a multiple of times (1 to 32767) with one INITiate command and when INITiate:CONTinuous OFF | 0 is set.

## Parameters

| Parameter Name | Parameter Type | Range of Values       |
|----------------|----------------|-----------------------|
| <i>number</i>  | Numeric        | 1 - 32767   MIN   MAX |

## Comments

- **Number of Scans:** Use only values between 1 to 32767 for the number of scanning cycles (default is 1).
- **Related Commands:** ABORt, INITiate[:IMMediate]
- **\*RST Condition:** ARM:COUNT 1

## Example Setting Ten Scanning Cycles

|                 |                               |
|-----------------|-------------------------------|
| ARM:COUN 10     | <i>Set 10 scanning cycles</i> |
| SCAN (@100:131) | <i>Sets channel list</i>      |
| INIT            | <i>Starts scanning cycle</i>  |

**:COUNT?** **ARM:COUNT? [MIN | MAX]** returns current number of scanning cycles set by ARM:COUNT. ARM:COUN? MIN returns 1 and ARM:COUN? MAX returns 32767.

## Parameters

| Parameter Name | Parameter Type | Range of Values      |
|----------------|----------------|----------------------|
| MIN   MAX      | Numeric        | MIN = 1, MAX = 32767 |

## Comments

- **Related Commands:** INITiate[:IMMediate]

## Example Query Number of Scanning Cycles

|             |                                                              |
|-------------|--------------------------------------------------------------|
| ARM:COUN 10 | <i>Sets 10 scanning cycles</i>                               |
| ARM COUN?   | <i>Query number of scanning cycles; returned value is 10</i> |

# DISPlay

The DISPlay subsystem monitors the channel state of a selected module (or card). This command can only be used when the FET multiplexer module is used in a switchbox configuration. It operates with mainframes that have a display, such as the HP 75000 Series B Mainframe (HP Model Number E1301). It also operates with terminals connected to the serial interface port.

## Subsystem Syntax

```
DISPlay
:MONitor
:CARD <number | AUTO>
[:STATe] <mode>
```

## :MONitor:CARD

**DISPlay:MONitor:CARD <number | AUTO>** selects the module in a switchbox to be monitored.

## Parameters

| Parameter Name       | Parameter Type | Range of Values |
|----------------------|----------------|-----------------|
| <i>number</i>   AUTO | Numeric        | 1 - 99          |

## Comments

- **Selecting a Specific Module to be Monitored:** Send the card number in a switchbox with the DISPlay:MONitor:CARD command.
- **Selecting the Present Module to be Monitored:** Use the DISPlay:MONitor:CARD AUTO command to select the last module addressed by a switching command (e.g., [ROUTE:]CLOSe).
- **\*RST Condition:** DISPlay:MONitor:CARD AUTO

## Example

### Select Module #2 in a Switchbox for Monitoring

```
DISP:MON:CARD 2
```

*Selects module #2 in a switchbox*

**:MONitor[:STATe]** **DISPlay:MONitor[:STATe]** *<mode>* turns the monitor mode on or off.

### Parameters

| Parameter Name | Parameter Type | Range of Values  |
|----------------|----------------|------------------|
| <i>mode</i>    | Boolean        | 0   1   ON   OFF |

### Comments

- **Monitoring Switchbox Channels:** **DISPlay:MONitor[:STATe]** ON or **DISPlay:MONitor[:STATe]** 1 turns the monitor mode on to show the channel state of the selected module. **DISPlay:MONitor[:STATe]** OFF or **DISPlay:MONitor[:STATe]** 0 turns the monitor mode off.
- **Selecting the Module to be Monitored:** Use the **DISPlay MONitor:CARD <number> | AUTO** command to select the module.
- **Monitor Mode on an HP 1301 Mainframe Display:** The following three examples show the types of display you will get:
  - Chan: \_ *No channels closed on this card*
  - Chan: 12 *Channel 12 closed*
- **\*RST Condition:** **DISPlay:MONitor[:STATe]** OFF | 0

### Example Enabling the Monitor Mode

DISP:MON:CARD 2 *Selects module #2 in a switchbox*  
DISP:MON 1 *Turns the monitor mode on*

# INITiate

The INITiate subsystem selects continuous scanning cycles and starts the scanning cycle.

## Subsystem Syntax

```
INITiate
:CONTinuous <mode>
:CONTinuous?
[:IMMEDIATE]
```

## :CONTinuous

**INITiate:CONTinuous <mode>** enables or disables continuous scanning cycles for the switchbox or scanning voltmeter.

## Parameters

| Parameter Name | Parameter Type | Range of Values  |
|----------------|----------------|------------------|
| <i>mode</i>    | Boolean        | 0   1   ON   OFF |

## Comments

- **Continuous Scanning Operation:** Continuous scanning is enabled with the INITiate:CONTinuous ON or INITiate:CONTinuous 1 command. Sending the INITiate[:IMMEDIATE] command closes the first channel in the *channel list*. Each trigger from a trigger source selected by the TRIGger:SOURce command advances the scan through the *channel list*. A trigger at the end of the *channel list* closes the first channel in the list and the scan cycle repeats. Continuous scanning can be stopped by the ABORT command for non-downloaded scans, and by a system reset or a power off for downloaded scan lists.
- **Scanning a Set Number of Cycles:** The INITiate:CONTinuous OFF or INITiate:CONTinuous 0 command goes through the scan list the number of times specified by the ARM:COUNT command. Sending the INITiate[:IMMEDIATE] command closes the first channel in the *channel list*. Each trigger from a trigger source selected by the TRIGger:SOURce command advances the scan through the *channel list*. A trigger at the end of the *channel list* opens the last channel in the list, and if the number of cycles has not reached the ARM:COUNT parameter, returns to the beginning of the scan list and closes the first channel. When the number of cycles equals the ARM:COUNT parameter, the scanning cycle stops. Note that ARM:COUNT does not apply to downloaded scan lists.
- **Stopping Continuous Scans:** Continuous scanning can be stopped by the ABORT command for non-downloaded scans, and by a system reset or a power off for downloaded scan lists.
- **Related Commands:** ABORT, ARM:COUNT, \*RST, TRIGger, TRIGger:SOURce
- **\*RST Condition:** INITiate:CONTinuous OFF

**Example Enabling Continuous Scans**

|                 |                                    |
|-----------------|------------------------------------|
| INIT:CONT ON    | <i>Enables continuous scanning</i> |
| SCAN (@100:131) | <i>Sets channel list</i>           |
| INIT            | <i>Starts scanning cycle</i>       |

**:CONTInuous?** **INITiate:CONTInuous?** queries the scanning state. With continuous scanning enabled, the command returns 1. With continuous scanning disabled, the command returns 0.

**Example Query Continuous Scanning State**

|              |                                        |
|--------------|----------------------------------------|
| INIT:CONT ON | <i>Enables continuous scanning</i>     |
| INIT:CONT?   | <i>Query continuous scanning state</i> |

**[:IMMediate]** **INITiate[:IMMediate]** starts the scanning cycle and closes the first channel in the *channel list*. Successive triggers from the source specified by the TRIGger:SOURce command advance the scan through the *channel list*.

- Comments**
- **Starting the Scanning Cycle:** The INITiate[:IMMediate] command starts scanning by closing the first channel in the *channel list*. A trigger advances the scan through the *channel list*. An invalid *channel list* generates an error (see the [ROUTE:]SCAN command).
  - **Stopping Scanning Cycles:** See the ABORt command.

**Example Enabling a Single Scan**

|                 |                              |
|-----------------|------------------------------|
| SCAN (@100:131) | <i>Sets channel list</i>     |
| INIT            | <i>Starts scanning cycle</i> |





# [ROUTE:]

The [ROUTE:] subsystem controls switching and scanning operations for the multiplexer modules in a switchbox.

## Subsystem Syntax

```
[ROUTE:]
 CLOSe <channel_list>
 CLOSe? <channel_list>
 OPEN <channel_list>
 OPEN? <channel_list>
 SCAN <channel_list>
 :MODE <mode>
 :MODE?
 :PORT <port>
 SETTling
 [:TIME] <time>, <channel_list>
 [:TIME]? [MIN | MAX] <channel_list>
```

## CLOSe

[ROUTE:]CLOSe <channel\_list> closes multiplexer channels specified in the *channel list*. The *channel list* for CLOSe is in the form (@ccnn), or in special circumstances, (@ccnn,ccnn), where cc = card number (00-99) and nn = channel number (00-31). Before using the CLOSe command, you must specify the SCAN:MODE and SCAN:PORT, as these commands determine what switches will be closed for a given channel. You can only have one closed channel on a card at a time. If you want to close a channel on two different cards in the same VXIbus instrument (e.g., 102,208) you can use (@ccnn,ccnn).

## Parameters

| Parameter Name      | Parameter Type | Range of Values |
|---------------------|----------------|-----------------|
| <i>channel_list</i> | Numeric        | cc00 - cc31     |

## Comments

- **Specify SCAN:MODE and SCAN:PORT:** Before using the CLOSe command, specify the SCAN:MODE and SCAN:PORT.
- **Closing Channels:** To close:
  - a single channel, use [ROUTE:]CLOSe (@ccnn);
  - single channels on different cards, use [ROUTE:]CLOSe (@ccnn,ccnn);
  - for multiple channels, use [ROUTE:]CLOSe (@ccnn,ccnn);
  - sequential channels, use [ROUTE:]CLOSe (@ccnn:ccnn);
  - a group of sequential channels, use [ROUTE:]CLOSe (@ccnn:ccnn,ccnn:ccnn);
  - or any combination.

Closure order for multiple channels with a single command is not guaranteed.

- **Related Commands:** [ROUTE:]OPEN, [ROUTE:]CLOSe?, [ROUTE:]SCAN:MODE, [ROUTE:]SCAN:PORT
- **\*RST Condition:** All multiplexer channels are open.

## Example Closing Multiplexer Channels

This example closes channel 00 of a card number 1 multiplexer module and channel 31 of a card number 2 multiplexer module in a single switchbox.

```
SCAN:MODE VOLT
SCAN:PORT ABUS
CLOS (@100,231) 100 closes channel 00 of mux #1;
 231 closes channel 31 of mux #2
```

**CLOSe?** [ROUTE:]CLOSe? <channel\_list> returns the current state of the channel queried. The *channel\_list* is in the form (@ccnn). The command returns 1 if the channel is closed or returns 0 if the channel is open.

**Comments**

- **Query is Software Readback:** The [ROUTE:]CLOSe? command returns the current software state of the channel specified. It does not account for relay hardware failures.

## Example Query Multiplexer Channel Closure

```
CLOS (@100,231) 100 closes channel 00 of
 multiplexer #1; 231 closes channel
 31 of multiplexer #2

CLOS? (@231) Query channel 231
```

**OPEN** [ROUTE:]OPEN <channel\_list> opens the multiplexer channels specified in the *channel\_list*. The *channel\_list* is in the form (@ccnn), (@ccnn,ccnn), (@ccnn:ccnn) or (@ccnn:ccnn,ccnn:ccnn) where cc = card number (00-99) and nn = channel number (00-31).

## Parameters

| Parameter Name      | Parameter Type | Range of Values |
|---------------------|----------------|-----------------|
| <i>channel_list</i> | Numeric        | cc00 - cc31     |

**Comments**

- **Opening Channels:** To open:
  - a single channel, use [ROUTE:]OPEN (@ccnn);
  - for multiple channels, use [ROUTE:]OPEN (@ccnn,ccnn);
  - sequential channels, use [ROUTE:]OPEN (@ccnn:ccnn);
  - a group of sequential channels, use [ROUTE:]OPEN (@ccnn:ccnn,ccnn:ccnn);
  - or any combination.

Opening order for multiple channels with a single command is not guaranteed.

- **Open Channels:** Opening an already open channel has no effect.
- **Related Commands:** [ROUTE:]CLOSe, [ROUTE:]OPEN?
- **\*RST Condition:** All multiplexer channels are open.

## Example Opening Multiplexer Channels

This example opens channel 00 of a card number 1 multiplexer module and channel 31 of a card number 2 multiplexer module in a single switchbox.

```
OPEN (@100,231) 100 opens channel 00 of mux #1;
 231 opens channel 31 of mux #2
```

**OPEN?** [ROUTE:]OPEN? <channel\_list> returns the current state of the channel queried. The *channel list* is in the form (@ccnn). The command returns 1 if the channel is open or returns 0 if the channel is closed.

**Comments**

- **Query is Software Readback:** The [ROUTE:]OPEN? command returns the current software state of the channel specified. It does not account for relay hardware failures.

## Example Query Multiplexer Channel Open State

```
OPEN (@100,231) 100 opens channel 00 of mux #1;
 231 opens channel 31 of mux #2

OPEN? (@231) Query channel 231
```

**SCAN** [ROUTE:]SCAN <channel\_list> defines the channels to be scanned. The *channel\_list* has the form (@ccnn), (@ccnn,ccnn), (@ccnn:ccnn) or (@ccnn:ccnn,ccnn:ccnn) where cc = card number (00-99) and nn = channel number (00-31).

## Parameters

| Parameter Name      | Parameter Type | Range of Values |
|---------------------|----------------|-----------------|
| <i>channel_list</i> | Numeric        | cc00 - cc31     |

**Comments**

- **Channel List:** Valid *channel lists* are:
  - a single channel, use (@ccnn);
  - for multiple channels, use (@ccnn,ccnn);
  - sequential channels, use (@ccnn:ccnn);
  - a group of sequential channels, use (@ccnn:ccnn,ccnn:ccnn);
  - or any combination.
- **Defining the Channel List.** When executing [ROUTE:]SCAN, the *channel list* is checked for valid card and channel numbers. An error is generated for an invalid *channel list*.
- **Downloading a Scanning List:** The *channel\_list* is automatically downloaded into RAM on the FET multiplexer modules for TRIG:SOUR DBUS and TRIG:SOUR IMM trigger modes. The complete list is downloaded onto each module in an instrument. The channels are advanced with no direct intervention by the mainframe CPU during the scan. If an instrument contains mixed modules (FET and Relay Multiplexers), the scan list will not be downloaded.

- **Scanning Operation:** With a valid *channel list*, INITiate[:IMMediate] starts the scanning cycle and closes the first channel in the *channel list*. Successive triggers from the source specified by TRIGger:SOURce advances the scan through the *channel list*.
- **Stopping Scan:** See the ABORt command.
- **Related Commands:** TRIGger, TRIGger:SOURce
- **\*RST Condition:** All multiplexers channels are open.

### Example Scanning Using External Instruments

The following example shows how to scan channels using the HP E1300/E1301 Mainframe via HP-IB and an HP 3457A Digital Multimeter. This example uses the mainframe "Trig Out" port to synchronize the multiplexer module in a switchbox to the multimeter. The trigger pulse from the port triggers the multimeter for a measurement. See Chapter 3 for typical user connections to the multiplexer.

The computer used in the example is an HP Series 200/300 with HP BASIC as the program language. The computer interfaces with the mainframe over HP-IB. Assumed is an HP-IB select code of 7, an HP-IB primary address of 09 and 22 for the HP E1300/E1301 Mainframe and HP 3457A Multimeter, respectively, and an HP-IB secondary address of 14 for the switchbox.

```

10 OUTPUT 722;"TRIG EXT;DCV" !Sets multimeter to external trigger
 and to measure dc volts
20 OUTPUT 70914;"OUTP ON" !Enables "Trig Out" port
30 OUTPUT 70914;"TRIG:SOUR BUS" !Sets switchbox to receive bus
 triggers
40 OUTPUT 70914;"SCAN:MODE VOLT"!Sets switchbox to measure
 voltage during scanning
50 OUTPUT 70914;"SCAN:PORT ABUS"!Sets switchbox to close the
 appropriate tree switches during
 scanning
60 OUTPUT 70914;"SCAN (@100:131)!Selects the channel list
70 OUTPUT 70914;"INIT" !Starts scanning cycle
80 FOR I = 1 TO 32 !Start count loop
90 ENTER 722;A !Enter reading into variable A
100 PRINT A !Print reading in variable A
110 TRIGGER 70914 !Trigger the switchbox to advance
 the channel list
120 NEXT I !Increment count
130 END

```

**SCAN:MODE** [ROUTE:]SCAN:MODE <mode> sets the multiplexer channels defined by the [ROUTE:]SCAN <channel\_list> command for None, Volts or 2-wire Ohms measurements.

### Parameters

| Parameter Name | Parameter Type | Range of Values   |
|----------------|----------------|-------------------|
| <i>mode</i>    | Discrete       | NONE   VOLT   RES |

### Comments

- **Order of Command Execution:** The [ROUTE:]SCAN:MODE command must be executed before the [ROUTE:]SCAN <channel\_list> and [ROUTE:]CLOSE <channel\_list> commands.
- **NONE and VOLT Mode Description:** Channel list is set up for volts measurements.
- **RES Mode Description:** Channel list is set up for 2-wire ohms measurements. The current source on I+ and I- is superimposed on the channel being measured. Appropriate tree isolation switches are automatically closed.
- **\*RST Condition:** [ROUTE:]SCAN:MODE NONE

**Example** **Selecting the 2-Wire Ohms Mode.** This example scans 32 channels for 2-wire resistance measurements.

```
TRIG:SOUR EXT Selects external trigger source
SCAN:MODE RES Selects the 2-wire ohms scanning mode
SCAN (@100:131) Sets channel list
INIT Starts scanning cycle
```

**SCAN:MODE?** [ROUTE:]SCAN:MODE? returns the current state of the scan mode. The command returns NONE, VOLT, or RES if the scan mode is in the NONE, VOLT, or RES mode, respectively.

**Example** **Query Scan Mode**

Since this example selects the RES (2-wire ohms) mode, the query command returns RES.

```
SCAN:MODE RES Selects the 2-wire ohms scanning mode
SCAN:MODE? Query the scanning mode
```

## SCAN:PORT

[ROUTe:]SCAN:PORT <port> enables/disables the tree isolation switches. SCAN:PORT ABUS closes the appropriate tree switches (for analog bus connections). The [ROUTe:]SCAN:PORT NONE command disables the tree switches and leaves them open. With SCAN:PORT NONE the closed channels cannot be measured.

### Parameters

| Parameter Name | Parameter Type | Range of Values |
|----------------|----------------|-----------------|
| <i>port</i>    | Discrete       | ABUS   NONE     |

### Comments

- **Order of Command Execution:** The [ROUTe:]SCAN:PORT command must be executed before the [ROUTe:]SCAN <channel\_list> and [ROUTe:]CLOSe <channel\_list> commands.
- **\*RST Condition:** [ROUTe:]SCAN:PORT NONE

### Example Selecting the ABUS Port

|                 |                                              |
|-----------------|----------------------------------------------|
| TRIG:SOUR EXT   | <i>Selects external trigger source</i>       |
| SCAN:MODE RES   | <i>Selects the 2-wire ohms scanning mode</i> |
| SCAN:PORT ABUS  | <i>Selects the ABUS port</i>                 |
| SCAN (@100:107) | <i>Sets channel list</i>                     |
| INIT            | <i>Starts scanning cycle</i>                 |

## SETTling[:TIME]

[ROUTe:]SETTling[:TIME] <channel\_list> sets the delay between receipt of trigger command and activation of the "Channel Closed" on the digital bus. You must specify one and only one channel for each card in the instrument which has a channel on the *channel list*, and the <time> will then apply to all channels on the card. The range is 1 to 32768  $\mu$ sec.

### Parameters

| Parameter Name      | Parameter Type | Range of Values             |
|---------------------|----------------|-----------------------------|
| <i>time</i>         | Numeric        | 1E-6   32768E-6   MIN   MAX |
| <i>channel_list</i> | Numeric        | only one channel            |

### Comments

- **Digital Bus Handshaking:** This command allows a user-defined delay before multimeter starts a reading.
- **Related Commands:** TRIGger:SOURce DBUS

### Example Setting 16 $\mu$ sec SETTling TIME

|                     |                                                      |
|---------------------|------------------------------------------------------|
| TRIGger:SOUR DBUS   | <i>Triggering on the digital bus handshake lines</i> |
| SETTling:TIME 16E-6 | <i>Delay = 16<math>\mu</math>sec</i>                 |

**SETTling[:TIME]?** [ROUTE:]SETTling[:TIME]? [MIN | MAX] <channel\_list> returns the current setting for a specified channel. MIN or MAX returns the minimum and maximum allowable settings.

### Parameters

| Parameter Name | Parameter Type | Range of Values                          |
|----------------|----------------|------------------------------------------|
| MIN   MAX      | Numeric        | MIN = 1 $\mu$ sec, MAX = 32768 $\mu$ sec |
| channel_list   | Numeric        | only one channel                         |

### Comments

- Returned value is given in exponential notation.

### Example

SETTling:TIME 16E-6

*Sets delay = 16 $\mu$ sec*

SETTling:TIME?

*Returns + 1.600000E-005*

# STATus

The STATus subsystem reports the bit values of the Operation Status Register. It enables the Status Register to set a bit after a bit is set to 1 by the Operation Status Register.

## Subsystem Syntax

```
STATus
:OPERation
 :ENABLE <number>
 [:EVENT]?
```

## :OPERation:ENABLE

**STATus:OPERation:ENABLE <number>** enables the Operation Status Register to set a bit in the Status Register. For multiplexer modules, when bit 8 in the Operation Status Register is set to 1, bit 7 in the Status Register is set to 1.

## Parameters

| Parameter Name | Parameter Type | Range of Values |
|----------------|----------------|-----------------|
| <i>number</i>  | Numeric        | 1 - 32768       |

## Comments

- **Setting Bit 7 of the Status Register:** STATus:OPERation:ENABLE 256 sets bit 7 of the Status Register to 1 after bit 8 of the Operation Status Register is set to 1.
- **Disabling STATus:OPERation:** The STATus:PRESet command disables the STATus:OPERation:ENABLE command.
- **Related Commands:** [ROUTE:]SCAN, \*SRE, \*STB?, \*SPOLL, STATus:PRESet

## Example

### Enable the Status Register

```
STAT:OPER:ENAB 256
```

*Enables bit 7 of the Status Register*

## :OPERation[:EVENT]?

**STATus:OPERation[:EVENT]?** returns the bit value of the Operation Status Register (only bit 8 is used by the multiplexer modules).

## Comments

- **Setting Bit 8 of the Operation Status Register:** Bit 8 (Scan Complete) is set to 1 after a scanning cycle completes. Bit 8 returns to 0 after sending the STATus:OPERation[:EVENT]? command. For correct operation set to 0 by \*CLS before scanning.
- **Returned Data after sending the STATus:OPERation[:EVENT]? Command:** The command returns +256 if bit 8 of the Operation Status Register is set to 1. The command returns +0 if bit 8 of the Operation Status Register is set to 0.
- **Related Commands:** [ROUTE:]SCAN, \*SRE, \*STB?, \*SPOLL

## Example

### Reading the Operation Status Register after a Scanning Cycle

```
STAT:OPER?
```

*Reads the register value*

```
read and print the register value
```

*+256 shows bit 8 is set to 1; +0 shows bit 8 is set to 0*



# SYSTEM

The SYSTEM subsystem returns the error numbers and error messages in the error queue of a switchbox, and returns the types and descriptions of modules (cards) in a switchbox.

**Subsystem Syntax**

```
SYSTEM
:CDEscription? <number>
:CPON <number | ALL>
:CTYPe? <number>
:ERRor?
```

**:CDEscription?** **SYSTEM:CDEscription? <number>** returns the description of a selected module (card) in a switchbox.

## Parameters

| Parameter Name | Parameter Type | Range of Values |
|----------------|----------------|-----------------|
| <i>number</i>  | Numeric        | 1 - 99          |

**Comments**

- **32-Channel FET Multiplexer Module Description:** The SYSTEM:CDEscription? <number> command returns:  

```
32 Channel Single-Ended FET Mux
```

## Example Reading the Description of Card #1 Module

```
SYST:CDES? 1 Determine the description
```

**:CPON** **SYSTEM:CPON <number | ALL>** opens all channels of selected, or all modules (cards) in a switchbox.

## Parameters

| Parameter Name | Parameter Type | Range of Values |
|----------------|----------------|-----------------|
| <i>number</i>  | numeric        | 1 -99           |

**Comments**

- **Differences between \*RST and CPON:** SYSTEM:CPON only opens all channels of a selected module or all modules in a switchbox. \*RST opens all channels of all modules in a switchbox and also sets the trigger, etc. modes to the power-on states.

## Example Setting a Card #1 Module to its Power-on State

```
SYST:CPON 1 Sets module #1 to power-on state
```

**:CTYPe?** **SYSTem:CTYPe? <number>** returns the module (card) type of a selected module in a switchbox.

### Parameters

| Parameter Name | Parameter Type | Range of Values |
|----------------|----------------|-----------------|
| <i>number</i>  | Numeric        | 1 - 99          |

### Comments

- **32-Channel FET Multiplexer Module Model Number:**  
The SYSTem:CTYPe? <number> command returns:

HEWLETT-PACKARD , E1352A , 0 , A . 03 . 00

Note: The first number after the E1352A model number is the serial number of the module (always 0); the module revision code follows the serial number.

### Example Reading the Model Number of a Card #1 Module

SYST:CTYP? 1 *Determine the model number*

**:ERRor?** **SYSTem:ERRor?** returns the error numbers and corresponding error messages in the error queue of a switchbox. See Appendix C for a listing of the switchbox error numbers and messages.

### Comments

- **Error Numbers/Messages in the Error Queue:** Errors generated by a switchbox store an error number and corresponding error message in the error queue. Each error message can be up to 255 characters long.
- **Clearing the Error Queue:** An error number/message is removed from the queue each time the SYSTem:ERRor? command is sent. The errors are cleared first-in, first-out. When the queue is empty, each following SYSTem:ERRor? command returns 0, "No error". To clear all error numbers/messages in the queue, execute \*CLS.
- **Maximum Error Numbers/Messages in the Error Queue:** The queue holds a maximum of 30 error numbers/messages for each switchbox. If the queue overflows, the last error number/message in the queue is replaced by -350, "Too many errors". The least recent error numbers/messages remain in the queue and the most recent are discarded.

### Example Reading the Error Queue

SYST:ERR? *Query the error queue*

# TRIGger

The TRIGger subsystem commands control the scan triggering operation of the multiplexer.

## Subsystem Syntax

```
TRIGger
[:IMMEDIATE]
:SOURce BUS | DBUS | EXTERNAL | HOLD | IMMEDIATE
:SOURce?
```

## [:IMMEDIATE]

**TRIGger[:IMMEDIATE]** causes a trigger to occur when the defined trigger source is TRIGger:SOURce HOLD or TRIGger:SOURce BUS. Note that TRIGger[:IMM] is not the same as TRIGger:SOURce IMM.

## Comments

- **Executing the TRIGger[:IMMEDIATE] Command:** A channel list must be defined with the [ROUTE:]SCAN <channel\_list> command and an INITiate[:IMMEDIATE] command must be executed before TRIGger[:IMMEDIATE] can trigger the switchbox.
- **HOLD or BUS Source Remains:** If selected, the TRIGger:SOURce HOLD or TRIGger:SOURce BUS commands remain in effect after triggering the switchbox with the TRIGger[:IMMEDIATE] command.
- **Related Commands:** INITiate, [ROUTE:]SCAN

## Example

### Advancing Scan using the TRIGger Command

|                 |                                              |
|-----------------|----------------------------------------------|
| TRIG:SOUR HOLD  | <i>Sets trigger source to hold</i>           |
| SCAN (@100:131) | <i>Sets channel list</i>                     |
| INIT            | <i>Starts scanning cycle</i>                 |
| loop statement  | <i>Start count loop</i>                      |
| TRIG            | <i>Advances channel list to next channel</i> |
| increment loop  | <i>Increment count loop</i>                  |

**:SOURce** TRIGger:SOURce BUS | DBUS | EXTERNAL | HOLD | IMMEDIATE specifies the trigger source to advance the *channel list* during scanning.

## Parameters

| Parameter Name | Parameter Type | Range of Values       |
|----------------|----------------|-----------------------|
| BUS            | Discrete       | *TRG command          |
| DBUS           | Discrete       | Digital Bus           |
| EXTERNAL       | Discrete       | Event In port         |
| HOLD           | Discrete       | Hold Triggering       |
| IMMEDIATE      | Discrete       | Continuous Triggering |

## Comments

- **Enabling the Trigger Source:** The TRIGger:SOURce command only selects the trigger source. The INITiate[:IMMEDIATE] command enables the trigger source.
- **Using the TRIG Command:** You can use TRIGger[:IMMEDIATE] to advance the scan when TRIGger:SOURce BUS or TRIGger:SOURce HOLD is selected.
- **Using Digital Bus Trigger:** TRIGger:SOURce DBUS selects the digital bus on the multiplexer as the trigger. Any open collector TTL trigger source can be wired to the "Channel Advance" lead. A negative-going pulse triggers the multiplexer and advances it to the next channel on the scanning list. After the SETTling:TIME delay, the multiplexer asserts "Channel Closed" on the digital bus.
- **Using External Trigger Inputs:** With TRIGger:SOURce EXTERNAL selected, only one switchbox at a time can use the external trigger input at the HP E1300/E1301 Mainframe "Event In" port. The trigger input is assigned to the first switchbox requesting the external trigger source.
- **Assigning External Trigger:** A switchbox assigned with TRIG:SOUR EXT remains assigned to that source until it receives a command to change the source. When the source is changed, the external trigger source is available to another switchbox (with a TRIGger:SOURce EXTERNAL command). Another switchbox cannot receive an external trigger source if the source is already assigned, or an error is generated.
- **Using Bus Triggers:** To trigger the switchbox with TRIGger:SOURce BUS selected, use TRIGger[:IMMEDIATE], the IEEE 488.2 common command \*TRG or the HP-IB Group Execute Trigger (GET).
- **"Trig Out" Port Shared by Switchboxes:** See the OUTPut command.
- **Related Commands:** [ROUTE:]SCAN, TRIGger, ABORT, SETTling[:TIME]
- **\*RST Condition:** TRIGger:SOURce IMMEDIATE

### Example Scanning Using External Triggers

In the following example, the trigger input is applied to the HP E1300/E1301 Mainframe "Event In" port.

|                    |                                              |
|--------------------|----------------------------------------------|
| TRIG:SOUR EXT      | <i>Sets trigger source to external</i>       |
| SCAN (@100:131)    | <i>Sets channel list</i>                     |
| INIT               | <i>Starts scanning cycle</i>                 |
| trigger externally | <i>Advances channel list to next channel</i> |

### Scanning Using Bus Triggers

|                 |                                           |
|-----------------|-------------------------------------------|
| TRIG:SOUR BUS   | <i>Sets interface (bus) triggering</i>    |
| SCAN (@100:131) | <i>Sets channel list</i>                  |
| INIT            | <i>Starts scanning cycle</i>              |
| *TRG            | <i>Advances scan using bus triggering</i> |

**:SOURce?** **TRIGger:SOURce?** returns the current trigger source for the switchbox. Command returns either BUS, DBUS, EXT, HOLD, or IMM for trigger sources BUS, DBUS, EXTERNAL, HOLD, or IMMEDIATE, respectively.

### Example Query Trigger Source

|               |                                            |
|---------------|--------------------------------------------|
| TRIG:SOUR EXT | <i>Sets trigger source to external</i>     |
| TRIG:SOUR?    | <i>Query trigger source; returns "EXT"</i> |

# IEEE 488.2 Common Commands

The following table lists the IEEE 488.2 Common (\*) Commands that the 32-Channel Single-Ended FET Multiplexer Modules accept. The operation of some of these commands is described in Chapter 4 of this manual. For more information on Common Commands, refer to the *HP 75000 Series B Mainframe User's Manual* (HP Model Number E1300/E1301) or the *ANSI/IEEE Standard 488.2-1987*.

| Command                                                                                                                                                                                                                      | Title                                                  | Description                                                                                                                      |
|------------------------------------------------------------------------------------------------------------------------------------------------------------------------------------------------------------------------------|--------------------------------------------------------|----------------------------------------------------------------------------------------------------------------------------------|
| *IDN?                                                                                                                                                                                                                        | Identification                                         | Returns identification string of the switchbox.                                                                                  |
| *RST                                                                                                                                                                                                                         | Reset                                                  | Opens all channels, and invalidates current <i>channel list</i> for scanning. Sets ARM:COUN 1, TRIG:SOUR IMM, and INIT:CONT OFF. |
| *TST?                                                                                                                                                                                                                        | Self-Test                                              | Power-on interrupt returns +110<br>Incorrect MFR ID or model code returns +103<br>Test pass returns 0.                           |
| *OPC<br>*OPC?                                                                                                                                                                                                                | Operation Complete<br>Operation Complete Query         | See note below.<br>See note below.                                                                                               |
| *WAI                                                                                                                                                                                                                         | Wait to Complete                                       | See note below.                                                                                                                  |
| *CLS                                                                                                                                                                                                                         | Clear status                                           | Clears all status registers (see STATus:OPERation[:EVENT]?).                                                                     |
| *ESE<br>*ESE?                                                                                                                                                                                                                | Event status enable<br>Event status enable query       | See note below.<br>See note below.                                                                                               |
| *ESR?                                                                                                                                                                                                                        | Event status register query                            | See note below.                                                                                                                  |
| *SRE<br>*SRE?                                                                                                                                                                                                                | Service request enable<br>Service request enable query | Enables status register bits (see Chapter 4 for operation).<br>See note below.                                                   |
| *STB?                                                                                                                                                                                                                        | Read status byte query                                 | See note below.                                                                                                                  |
| *TRG                                                                                                                                                                                                                         | Trigger                                                | Triggers the switchbox to advance the scan when scan is enabled and trigger source is TRIGger:SOURce BUS   HOLD.                 |
| *RCL                                                                                                                                                                                                                         | Recall instrument state                                | See note below.                                                                                                                  |
| *SAV                                                                                                                                                                                                                         | Store instrument state                                 | See note below.                                                                                                                  |
| Note: These commands apply to many instruments and are not documented in detail here. See the <i>HP 75000 Series B E1300/E1301 Mainframe User's Manual</i> or the <i>ANSI/IEEE Standard 488.2-1987</i> for more information. |                                                        |                                                                                                                                  |

# Command Quick Reference

The following tables summarize SCPI and IEEE 488.2 Common (\*) Commands for the 32-Channel Single-Ended FET Multiplexer Modules.

## SCPI Commands Quick Reference

| Command                                                                                                                                                                                                                                                                                    | Description                                                                                                                                                                                                                                                                                                                                                                                                      |
|--------------------------------------------------------------------------------------------------------------------------------------------------------------------------------------------------------------------------------------------------------------------------------------------|------------------------------------------------------------------------------------------------------------------------------------------------------------------------------------------------------------------------------------------------------------------------------------------------------------------------------------------------------------------------------------------------------------------|
| ABORT                                                                                                                                                                                                                                                                                      | Abort a scan in progress.                                                                                                                                                                                                                                                                                                                                                                                        |
| ARM<br>:COUNt <number> MIN   MAX<br>:COUNT? [MIN   MAX]                                                                                                                                                                                                                                    | Multiple scans per INIT command.<br>Query number of scans.                                                                                                                                                                                                                                                                                                                                                       |
| DISPlay<br>:MONitor:CARD <number>   AUTO<br>:MONitor[:STATe] <mode>                                                                                                                                                                                                                        | Selects module to be monitored.<br>Selects monitor mode.                                                                                                                                                                                                                                                                                                                                                         |
| INITiate<br>:CONTinuous <mode><br>:CONTinuous?<br>[:IMMediate]                                                                                                                                                                                                                             | Enables/disables continuous scanning.<br>Query mode.<br>Starts a scanning cycle.                                                                                                                                                                                                                                                                                                                                 |
| OUTPut<br>[:STATe] <state><br>[:STATe]?                                                                                                                                                                                                                                                    | Enables/disables "Trig Out" pulse.<br>Query state of trig out pulse.                                                                                                                                                                                                                                                                                                                                             |
| [ROUte:]<br>CLOSe <channel_list><br>CLOSe? <channel_list><br>OPEN <channel_list><br>OPEN? <channel_list><br>SCAN <channel_list><br>SCAN:MODE NONE   VOLT   RES<br>SCAN:MODE?<br>SCAN:PORT NONE   ABUS<br><br>SETTling[:TIME] <channel_list><br>SETTling[:TIME]? [MIN   MAX] <channel_list> | Close channel(s).<br>Query channel(s) closed.<br>Open channel(s).<br>Query channel(s) opened.<br>Define channels for scanning.<br>Selects appropriate tree Isolation switches for measurements.<br>Query state of scan mode.<br>Enables tree isolation switches closure as part of a measurement.<br>Sets delay between trigger pulse and channel closed pulse.<br>Returns current parameter in SETTling[:TIME]. |
| STATus<br>:OPERation:ENABLE<br>:OPERation[:EVENT]?                                                                                                                                                                                                                                         | Enables the Operation Status Register to set a bit in the Status Register.<br>Returns status of Operation Status Register.                                                                                                                                                                                                                                                                                       |
| SYSTem<br>:CDEscription? <number><br>:CPON <number>   ALL<br>:CTYPe? <number><br>:ERRor?                                                                                                                                                                                                   | Returns description of module in a switchbox.<br>Sets specified module to its power-on state.<br>Returns the module type.<br>Returns error number/message in a switchbox error queue.                                                                                                                                                                                                                            |
| TRIGger<br>[:IMMediate]<br>:SOURce BUS<br>:SOURce DBUS<br>:SOURce EXTernal<br>:SOURce HOLD<br>:SOURce IMMEDIATE<br>:SOURce?                                                                                                                                                                | Causes a trigger to occur.<br>Trigger source is *TRG.<br>Trigger source is Digital Bus.<br>Trigger source is "Event In" port.<br>Hold off triggering.<br>Continuous (internal) triggers.<br>Query scan trigger source.                                                                                                                                                                                           |

## IEEE 488.2 Common Commands Quick Reference

| Command | Title       | Description                                                                                                                  |
|---------|-------------|------------------------------------------------------------------------------------------------------------------------------|
| *RST    | Reset       | Opens all channels, invalidates current channel list for scanning.<br>Sets ARM:COUN 1, TRIG:SOUR IMM, and INIT:CONT OFF.     |
| *TRG    | Bus Trigger | When scan is enabled and trigger source is TRIG:SOUR BUS, use the *TRG command to trigger the switchbox to advance the scan. |
| *TST?   | Self Test   | Power on interrupt returns +110. Incorrect MFR ID or model code returns +103.<br>Test passes returns 0.                      |





# Appendix A

## HP E1352A Specifications

---

**Maximum Voltage:**

Terminal to Chassis: 16V peak  
(input impedance less above 14V peak)

**Maximum Current per Channel:**

1 mA (non-inductive)

**Maximum Offset Voltage:**

25  $\mu$ V (0° to 28° C)  
250  $\mu$ V (28° to 55° C)

**Input Impedance:**

Power On ( $V_{in} < \pm 10V$ )  
High to Low:  $> 10^8 \Omega$   
High or Low to Chassis:  $> 10^8 \Omega$   
Guard to Chassis:  $10 k\Omega \pm 10\%$

**Capacitance:**

High or Low to chassis:  $< 200pf$   
High to Low:  $< 200pf$

**Power Off:**

High to Low:  
for  $V_{in} \leq 13V$ :  $1000\Omega$   
for  $V_{in} > 13V$ :  $220\Omega$

**Closed Channel Resistance:**

$< 3.1 k\Omega$  for high or low input  
(Guard not switched)

**Bandwidth (-3 dB):**

50 $\Omega$  source,  $1 M\Omega \parallel 10pf$   
termination:  $> 500 kHz$

**Screw Terminal Wire Size:**

16 AWG Max, 26 AWG Min

**Module Size/Device Type:**

B, register-based

**Connectors Used:** P1

**Number of Slots:** 1

**Interrupt Level:** selectable

**Power Requirements:**

|                                     |      |      |
|-------------------------------------|------|------|
| Voltage:                            | +5V  | +12V |
| Peak module<br>current, IPM (A):    | 0.20 | 0.13 |
| Dynamic module<br>current, IDM (A): | 0.01 | 0.01 |

**Strain Gage Excitation:**

+ 4.63V  $\pm 10\%$   
Max Current: 400mA  
(short circuit protected)

**Watts/Slot:** 1.0

**Cooling/slot:**

0.02 mm H<sub>2</sub>O @ 0.10 liter/sec

**Humidity:** 65% 0° to 40° C

**Operating Temperature:**

0 to 55° C

**Storage Temperature:**

-40° to 75° C

**EMC, RFI, Safety:**

meets FTZ 1046/1984, CSA 556B,  
IEC 348, UL 1244

**Net Weight (kg):** 0.9



# Appendix B

# HP E1352A Register-Based Programming

---

## About This Appendix

The HP E1352A 32-Channel Single-Ended FET Multiplexer is a register-based module which does not support the VXIbus word serial protocol. When a SCPI command is sent to the multiplexer, the HP E1405/E1406 Command Module (Series C) or HP E1300/01 Mainframe (Series B) parses the command and programs the multiplexer at the register level.

Register-based programming is a series of reads and writes directly to the multiplexer registers. This increases throughput speed since it eliminates command parsing and allows the use of an embedded controller. Also, if slot 0, the resource manager, and the computer interface (HP-IB) are provided by other devices, a C-size system can be down-sized by removing the Command Module.

This appendix contains the information you need for register-based programming. The contents include:

- Register Addressing . . . . . Page 75
- Register Descriptions . . . . . Page 78
- Register Bit Descriptions . . . . . Page 80
- Executing Commands . . . . . Page 85

## Register Addressing

Register addresses for register-based devices are located in the upper 25% of VXIbus A16 address space. Every VXIbus device (up to 256) is allocated a 64-byte block of addresses. The HP E1352A Multiplexer uses eight two-byte registers of the 64 addresses allocated.

Figure B-1 shows the register address location within A16. Figure B-2 shows the location of A16 address space in the HP E1405/E1406 Command Module and HP E1300A/01A Mainframe.

### The Base Address

When you are reading or writing to a multiplexer register, a hexadecimal or decimal register address is specified. This address consists of a base address plus a register offset. The base address used in register-based programming depends on whether the A16 address space is outside or inside the HP E1405/E1406 Command Module or HP E1300A/01A Mainframe.

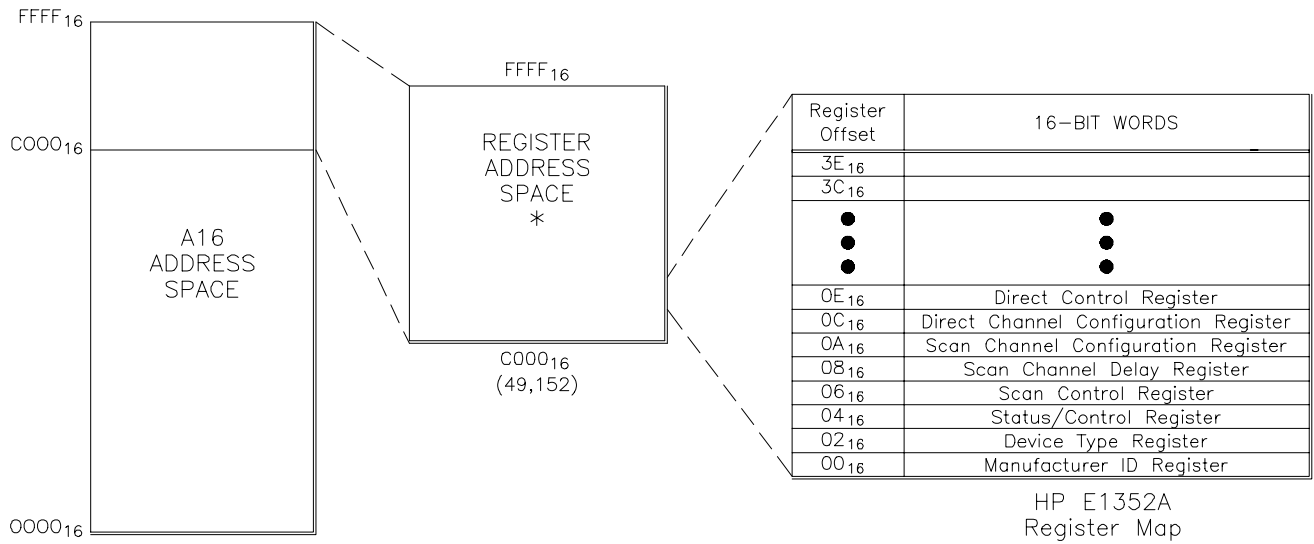

\*Base Address =  $C000_h + (Logical\ Address * 64)_{16}$   
 or  
 $49,152 + (Logical\ Address * 64)_{10}$

Register Address = Base address + Register Offset

**Figure B-1. Multiplexer Registers within A16 Address**

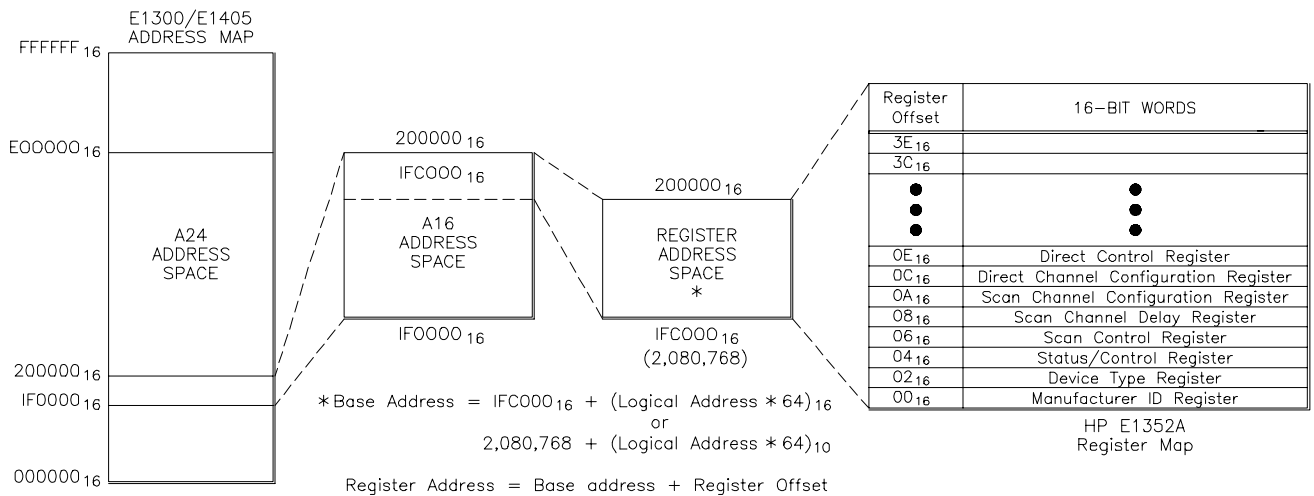

\*Base Address =  $IFC000_{16} + (Logical\ Address * 64)_{16}$   
 or  
 $2,080,768 + (Logical\ Address * 64)_{10}$

Register Address = Base address + Register Offset

**Figure B-2. Mainframe/Command Module A16 Address Space**

## A16 Address Space Outside the Command Module or Mainframe

When the Command Module or mainframe is not part of your VXIbus system (Figure B-1), the multiplexer's base address is computed as:

$$C000_{16} + (LADDR * 64)_{16}$$

*or*

$$49,152 + (LADDR * 64)$$

where  $C000_{16}$  (49,152) is the starting location of the register addresses, LADDR is the multiplexer's logical address, and 64 is the number of address bytes per VXIbus device. For example, if the multiplexer's logical address is 112, the multiplexer will have a base address of:

$$C000_{16} + (112 * 64)_{16}$$
$$C000_{16} + 1C00_{16} = DC00_{16}$$

*or (decimal)*

$$49,152 + (112 * 64)$$
$$49,152 + 7,168 = 56,320$$

## A16 Address Space Inside the Command Module or Mainframe

When the A16 address space is inside the command module or mainframe (Figure B-2), the multiplexer's base address is computed as:

$$1FC000_{16} + (LADDR * 64)_{16}$$

*or*

$$2,080,768 + (LADDR * 64)$$

where  $1FC000_{16}$  (2,080,768) is the starting location of the VXI A16 addresses, LADDR is the multiplexer's logical address, and 64 is the number of address bytes per register-based device. Again, if the multiplexer's logical address is 112, the multiplexer will have a base address of:

$$1FC000_{16} + (112 * 64)_{16}$$
$$1FC000_{16} + 1C00_{16} = 1FDC00_{16}$$

*or*

$$2,080,768 + (112 * 64)$$
$$2,080,768 + 7,168 = 2,087,936$$

## Register Offset

The register offset is the register's location in the block of 64 address bytes. For example, with a LADDR of 112 the multiplexer's Scan Channel Delay Register has an offset of  $08_{16}$ . When you write a command to this register, the offset is added to the base address to form the register address:

$$DC00_{16} + 08_{16} = DC08_{16} \quad (\text{A16 outside the command module})$$
$$1FDC00_{16} + 08_{16} = 1FDC08_{16} \quad (\text{A16 inside the command module})$$

*or*

$$56,320 + 8 = 56,328 \quad (\text{A16 outside the command module})$$
$$2,087,936 + 8 = 2,087,944 \quad (\text{A16 inside the command module})$$

# Register Descriptions

There are six WRITE and two READ-only registers on the multiplexer. You can READ-back three of the Write registers. This section contains a description and a bit map of each register. Note that the bit names with an asterisk (\*) after them are True (asserted) when low (zero). An X represents a "do not care" situation and a 1 always represents 1.

**WRITE Registers** The following WRITE registers are located on the multiplexer.

- Status/Control Register (base + 04<sub>16</sub>)
- Scan Control Register (base + 06<sub>16</sub>)
- Scan Channel Delay Register (base + 08<sub>16</sub>)
- Scan Channel Configuration Register (base + 0A<sub>16</sub>)
- Direct Channel Configuration Register (base + 0C<sub>16</sub>)
- Direct Control Register (base + 0E<sub>16</sub>)

**READ Registers** There are two READ-only registers and three READ-back registers.

- Manufacturer ID Register (base + 00<sub>16</sub>)
- Device Type Register (base + 02<sub>16</sub>)
- Status/Control Register (base + 04<sub>16</sub>)
- Scan Control Register (base + 06<sub>16</sub>)
- Scan Channel Delay Register (base + 08<sub>16</sub>)

## Manufacturer ID Register

|                         |              |    |               |    |                 |    |   |   |   |   |   |   |   |   |   |   |
|-------------------------|--------------|----|---------------|----|-----------------|----|---|---|---|---|---|---|---|---|---|---|
| base + 00 <sub>16</sub> | 15           | 14 | 13            | 12 | 11              | 10 | 9 | 8 | 7 | 6 | 5 | 4 | 3 | 2 | 1 | 0 |
| Write                   | Undefined    |    |               |    |                 |    |   |   |   |   |   |   |   |   |   |   |
| Read                    | Device Class |    | Address Space |    | Manufacturer ID |    |   |   |   |   |   |   |   |   |   |   |

## Device Type Register

|                         |            |    |    |    |    |    |   |   |   |   |   |   |   |   |   |   |
|-------------------------|------------|----|----|----|----|----|---|---|---|---|---|---|---|---|---|---|
| base + 02 <sub>16</sub> | 15         | 14 | 13 | 12 | 11 | 10 | 9 | 8 | 7 | 6 | 5 | 4 | 3 | 2 | 1 | 0 |
| Write                   | Undefined  |    |    |    |    |    |   |   |   |   |   |   |   |   |   |   |
| Read                    | Model Code |    |    |    |    |    |   |   |   |   |   |   |   |   |   |   |

### Status/Control Register

| base + 04 <sub>16</sub> | 15        | 14 | 13 | 12 | 11 | 10 | 9 | 8 | 7 | 6 | 5 | 4       | 3   | 2      | 1    | 0       |
|-------------------------|-----------|----|----|----|----|----|---|---|---|---|---|---------|-----|--------|------|---------|
| Write                   | Undefined |    |    |    |    |    |   |   | X | X | X | TRG INT | DIR | IRQ EN | X    | CRD RST |
| Read                    | Undefined |    |    |    |    |    |   |   | 1 | 1 | 1 | BSY*    | 1   | 1      | IRQ* | IRQ EN* |

### Scan Control Register

| base + 06 <sub>16</sub> | 15        | 14 | 13 | 12 | 11 | 10 | 9 | 8 | 7 | 6 | 5 | 4       | 3      | 2      | 1      | 0       |
|-------------------------|-----------|----|----|----|----|----|---|---|---|---|---|---------|--------|--------|--------|---------|
| Write                   | Undefined |    |    |    |    |    |   |   | X | X | X | RST PTR | CNT EN | IMM EN | DBS EN | CLR SCN |
| Read                    | Undefined |    |    |    |    |    |   |   | 1 | 1 | 1 | 1       | CNT EN | IMM EN | DBS EN | CLR SCN |

### Scan Channel Delay Register

| base + 08 <sub>16</sub> | 15        | 14 | 13 | 12 | 11 | 10 | 9 | 8 | 7 | 6 | 5 | 4 | 3  | 2  | 1  | 0  |
|-------------------------|-----------|----|----|----|----|----|---|---|---|---|---|---|----|----|----|----|
| Write                   | Undefined |    |    |    |    |    |   |   | X | X | X | X | D3 | D2 | D1 | D0 |
| Read                    | Undefined |    |    |    |    |    |   |   | 1 | 1 | 1 | 1 | D3 | D2 | D1 | D0 |

### Scan Channel Configuration Register

| base + 0A <sub>16</sub> | 15        | 14   | 13   | 12 | 11 | 10 | 9 | 8 | 7 | 6 | 5 | 4  | 3  | 2  | 1  | 0  |
|-------------------------|-----------|------|------|----|----|----|---|---|---|---|---|----|----|----|----|----|
| Write                   | VLD*      | A_D* | B_D* | X  | C0 | X  | X | X | X | X | X | D4 | D3 | D2 | D1 | D0 |
| Read                    | Undefined |      |      |    |    |    |   |   |   |   |   |    |    |    |    |    |

### Direct Channel Configuration Register

| base + 0C <sub>16</sub> | 15        | 14 | 13 | 12 | 11 | 10 | 9 | 8 | 7 | 6 | 5 | 4  | 3  | 2  | 1  | 0  |
|-------------------------|-----------|----|----|----|----|----|---|---|---|---|---|----|----|----|----|----|
| Write                   | Undefined |    |    |    |    |    |   |   | X | X | X | D4 | D3 | D2 | D1 | D0 |
| Read                    | Undefined |    |    |    |    |    |   |   |   |   |   |    |    |    |    |    |

### Direct Control Register

| base + 0E <sub>16</sub> | 15        | 14 | 13 | 12 | 11 | 10 | 9 | 8 | 7 | 6 | 5 | 4    | 3    | 2    | 1 | 0  |
|-------------------------|-----------|----|----|----|----|----|---|---|---|---|---|------|------|------|---|----|
| Write                   | Undefined |    |    |    |    |    |   |   | X | X | X | VLD* | A_D* | B_D* | X | C0 |
| Read                    | Undefined |    |    |    |    |    |   |   |   |   |   |      |      |      |   |    |

# Register Bit Descriptions

This section contains a description of the function of each bit which is addressable in each register. The bits are listed according to the title of the WRITE bit name, with the READ definition at the end of the description. For registers 00<sub>16</sub> and 02<sub>16</sub>, the bits are listed according to the title of the READ definition.

## Manufacturer ID Register

The 32-Channel Single-Ended FET Multiplexer Module always returns FFFF<sub>16</sub> on a Manufacturer ID Register READ.

|                         |           |    |    |    |    |    |   |   |   |   |   |   |   |   |   |   |
|-------------------------|-----------|----|----|----|----|----|---|---|---|---|---|---|---|---|---|---|
| base + 00 <sub>16</sub> | 15        | 14 | 13 | 12 | 11 | 10 | 9 | 8 | 7 | 6 | 5 | 4 | 3 | 2 | 1 | 0 |
| Write                   | Undefined |    |    |    |    |    |   |   |   |   |   |   |   |   |   |   |
| Read                    | 1         | 1  | 1  | 1  | 1  | 1  | 1 | 1 | 1 | 1 | 1 | 1 | 1 | 1 | 1 | 1 |

**Device Class** There are four classifications. The FET Multiplexer Module is a register-based device (11).

**Address Space** The FET Multiplexer Module uses A16 address mode.

**Manufacturer ID** Hewlett-Packard's identification number is 4095, which corresponds to bits 11 - 0 all set to 1.

## Device Type Register

The Device Type Register contains a model code which identifies the module.

|                         |            |    |    |    |    |    |   |   |   |   |   |   |   |   |   |   |
|-------------------------|------------|----|----|----|----|----|---|---|---|---|---|---|---|---|---|---|
| base + 02 <sub>16</sub> | 15         | 14 | 13 | 12 | 11 | 10 | 9 | 8 | 7 | 6 | 5 | 4 | 3 | 2 | 1 | 0 |
| Write                   | Undefined  |    |    |    |    |    |   |   |   |   |   |   |   |   |   |   |
| Read                    | Model Code |    |    |    |    |    |   |   |   |   |   |   |   |   |   |   |

**Model Code** The model code for the HP E1352A 32-Channel Single-Ended FET Multiplexer is FF18<sub>16</sub>.



## Status/Control Register

The Status/Control WRITE register is used to reset the module, enable interrupts, choose direct or scan list control of the channels and to internally trigger channel closing. The READ register indicates if interrupts are enabled, if there is an interrupt and if the module is busy.

| base + 04 <sub>16</sub> | 15        | 14 | 13 | 12 | 11 | 10 | 9 | 8 | 7 | 6 | 5 | 4        | 3   | 2      | 1    | 0       |
|-------------------------|-----------|----|----|----|----|----|---|---|---|---|---|----------|-----|--------|------|---------|
| Write                   | Undefined |    |    |    |    |    |   |   | X | X | X | TRIG INT | DIR | IRQ EN | X    | CRD RST |
| Read                    | Undefined |    |    |    |    |    |   |   | 1 | 1 | 1 | BSY*     | 1   | 1      | IRQ* | IRQ EN* |

### Card Reset (CRD RST)

Writing a one (1) to bit 0 resets the multiplexer. Writing a zero turns the reset function off. You must write a zero after a reset or the module will not operate. The Reset conditions are: all Enables are set false, clear scan list, scan mode enabled (direct bit set 0), DELAY is 1 µsec and all channels opened.

### Interrupt Request Enable (IRQ EN)

Writing a one (1) enables the card to generate interrupts, a zero (0) disables it. Enabling this bit puts a zero (0) in IRQ EN\*.

### Direct (DIR)

Selects between direct control and scan list control. A zero (0) indicates scan list control and a one (1) indicates direct control. For scan list control the Direct Registers (base + 0C, base + 0E) are invalidated. For direct control the Scan Channel Configuration Register is invalidated.

### Trigger Internal (TRG INT)

Writing a one (1) immediately advances a channel on the scan list, a zero (0) is the idle state. Bit is automatically set back to zero (0) upon channel advance.

### Interrupt Request Enable (IRQ EN\*)

Reading a zero (0) indicates enabled, reading a one (1) indicates disabled.

### Interrupt Request (IRQ\*)

Reading a zero (0) indicates an interrupt, a one (1) indicates no interrupt. This bit remains one (1) if IRQ EN is disabled. Interrupt remains set until Card Reset or interrupt has been acknowledged.

### Busy (BSY\*)

This bit is set zero (0) during channel closing and the delay period. Triggers will not be accepted. BSY\* is unasserted at the beginning of the Channel Closed pulse. If a trigger occurs during the Channel Closed pulse, the pulse is terminated and the channel is advanced. Operates only with downloaded scan list (DIR is zero).

## Scan Control Register

The Scan Control Register allows you to clear the scan list, set the trigger mode and reset the pointer to the beginning of the scan list. This register is a read-back register, allowing you to verify the state of the WRITE register.

| base + 06 <sub>16</sub> | 15        | 14 | 13 | 12 | 11 | 10 | 9 | 8 | 7 | 6 | 5 | 4       | 3      | 2      | 1      | 0       |
|-------------------------|-----------|----|----|----|----|----|---|---|---|---|---|---------|--------|--------|--------|---------|
| Write                   | Undefined |    |    |    |    |    |   |   | X | X | X | RST PTR | CNT EN | IMM EN | DBS EN | CLR SCN |
| Read                    | Undefined |    |    |    |    |    |   |   | 1 | 1 | 1 | 1       | CNT EN | IMM EN | DBS EN | CLR SCN |

### Clear Scan List (CLR SCN)

Writing a one (1) in this bit clears the scan list. The bit must be set back to zero (0) after flushing. CLR SCN (Read) returns the state of the bit.

### Digital Bus Enable (DBS EN)

Writing a one (1) enables the digital bus trigger mode. A zero (0) disables it. DBS EN (Read) returns the state of the bit.

### Immediate Enable (IMM EN)

Writing a one (1) in this bit sets trigger to immediate, which means that as soon as the first channel is closed by the TRG INT, the entire scan list is run without any further triggering. Channel advance speed is determined by the delay time specified. This has extremely limited applications.

### Continuous Enable (CNT EN)

Writing a one (1) in this bit enables the card to continually cycle through the scan list. When this bit is enabled, the last channel in a scan list resets the pointer back to the beginning of the scan list.

### Reset Pointer (RST PTR)

Writing a one (1) resets the pointer back to the beginning of the scan list. CNT EN true automatically resets pointer at end of scan list. If CNT EN is set true, an interrupt also resets the pointer. If CNT EN is set false, the last channel in the scan list generates an interrupt if the channel is valid (VLD\* set true).

## Scan Channel Delay Register

The Scan Channel Delay Register sets the SETTLing:TIME, the time between receipt of a channel closing trigger and the Channel Closed pulse. The delay is  $2^n \mu\text{s}$  and  $n$  has a range of 0 to 15. D3 to D0 set  $n$ , and D0 is the least significant bit. This register is a read-back register, allowing you to verify the state of the WRITE register.

| base + 08 <sub>16</sub> | 15        | 14 | 13 | 12 | 11 | 10 | 9 | 8 | 7 | 6 | 5 | 4 | 3  | 2  | 1  | 0  |
|-------------------------|-----------|----|----|----|----|----|---|---|---|---|---|---|----|----|----|----|
| Write                   | Undefined |    |    |    |    |    |   |   | X | X | X | X | D3 | D2 | D1 | D0 |
| Read                    | Undefined |    |    |    |    |    |   |   | X | X | X | X | D3 | D2 | D1 | D0 |

### D3 - D0

D0 is the least significant bit, D3 is the most significant. These bits designate a number between 0 and 15 for  $n$ .

## Scan Channel Configuration Register

These bits set the *<channel\_list>* for a scan list, set the type of measurement and enable/disable the tree isolation switches. Note that the DIR in the Status/Control Register must be set false to enable this register.

|                         |           |      |      |    |    |    |   |   |   |   |   |    |    |    |    |    |
|-------------------------|-----------|------|------|----|----|----|---|---|---|---|---|----|----|----|----|----|
| base + 0A <sub>16</sub> | 15        | 14   | 13   | 12 | 11 | 10 | 9 | 8 | 7 | 6 | 5 | 4  | 3  | 2  | 1  | 0  |
| Write                   | VLD*      | A_D* | B_D* | X  | C0 | X  | X | X | X | X | X | D4 | D3 | D2 | D1 | D0 |
| Read                    | Undefined |      |      |    |    |    |   |   |   |   |   |    |    |    |    |    |

**D4 - D0** These bits set the channel number, with a range of 0 - 31. Bit D0 is the least significant bit, and bit D4 is the most significant.

**Configuration Bit (C0)** This bit determines the measurement mode as listed below.

|    |             |
|----|-------------|
| C0 |             |
| 0  | Volts       |
| 1  | 2-wire Ohms |

**B and A Tree Isolation Switch Disable (B-D\*, A-D\*)** A zero in either one disables the respective tree isolation switch. Generally, both are disabled together to equal the [ROUTE:]SCAN:PORT NONE command. Note that you cannot use the tree terminals or the analog bus connector if the trees are disabled.

**Valid Channel (VLD\*)** A zero indicates that the specified channel is valid. When entering a scan list the entire list must be loaded into each module. For the channels that are not on that module, the VLD\* must be set false. See [ROUTE:]SCAN *<channel\_list>* in the “Executing Commands” section in this Appendix.

## Direct Channel Configuration Register

The Direct Channel Configuration Register allows you to specify channels to be closed individually. Note that the DIR bit in the Status/Control Register must be set true for this register to be enabled.

|                         |           |    |    |    |    |    |   |   |   |   |   |    |    |    |    |    |
|-------------------------|-----------|----|----|----|----|----|---|---|---|---|---|----|----|----|----|----|
| base + 0C <sub>16</sub> | 15        | 14 | 13 | 12 | 11 | 10 | 9 | 8 | 7 | 6 | 5 | 4  | 3  | 2  | 1  | 0  |
| Write                   | Undefined |    |    |    |    |    |   |   | X | X | X | D4 | D3 | D2 | D1 | D0 |
| Read                    | Undefined |    |    |    |    |    |   |   |   |   |   |    |    |    |    |    |

**D4 - D0** These bits set the channel number, with a range of 0 - 31. Bit D0 is the least significant bit, and bit D4 is the most significant.

## Direct Control Register

The Direct Control Register allows you to set the controls for individual channels. Note that the DIR bit in the Status/Control Register must be set true for this register to be enabled.

| base + 0E <sub>16</sub> | 15        | 14 | 13 | 12 | 11 | 10 | 9 | 8 | 7 | 6 | 5    | 4    | 3    | 2 | 1  | 0 |
|-------------------------|-----------|----|----|----|----|----|---|---|---|---|------|------|------|---|----|---|
| Write                   | Undefined |    |    |    |    |    |   | X | X | X | VLD* | A_D* | B_D* | X | C0 |   |
| Read                    | Undefined |    |    |    |    |    |   |   |   |   |      |      |      |   |    |   |

**Configuration Bit (C0)** This bit determines the measurement mode as listed below.

|    |             |
|----|-------------|
| C0 |             |
| 0  | Volts       |
| 1  | 2-wire Ohms |

**B and A Tree Isolation Switch Disable (B-D\*, A-D\*)** A zero in either one disables the respective tree isolation switch. Generally, both are disabled together to equal the [ROUTE:;]SCAN:PORT NONE command. Note that you cannot use the tree terminals or the analog bus connector if the trees are disabled.

**Valid Channel (VLD\*)** A zero indicates that the channel is valid. The DIR bit in the Status/Control Register automatically sets this bit. If DIR is valid and IMM EN is true, a write to this register will generate an interrupt.

# Executing Commands

This command lists the SCPI commands and shows how to execute them with register-based programming. For further information on register-based programming see the *HP E1326B Multimeter User's Manual*.

**ABORt** **ABORt** does not have an equivalent in register-based programming. This command is executed from the front panel or over HP-IB.

**ARM:COUNT** The **ARM:COUNT** command does not have an equivalent in register-based programming. To scan for a specified number of cycles, use the interrupt generated at the end of the scan list to advance through a program loop for the set number of cycles. For each pass through the loop, reset the pointer to the beginning of the scan list. The IRQ EN in the Status/Control Register must be enabled.

**DISPlay:MONitor** The **DISPlay:MONitor[:STATe]** command does not have an equivalent in register-based programming. For high-speed operation it should be set to **DISPlay:MONitor OFF**.

**INITiate** **INITiate:CONTinuous** is equivalent to the CNT EN bit in the Scan Control Register.

**INITiate[:IMMediate]** is equivalent to writing a one to the TRG INT in the Status/Control Register. The TRG INT sets itself back to zero after pulsing the FET. If you have a multiple-module configuration and a downloaded scan list, the module with the first channel on the scan list must be the last one to receive the TRG INT. The scan cycle will start as soon as the card with a valid channel receives TRG INT.

**OUTPut** The **OUTPut[:STATe]** command does not have an equivalent in register-based programming.

**[ROUTE:]** **[ROUTE:]CLOSe <channel\_list>** is equivalent to the following:

- DIR in the Status/Control Register is enabled.
- D0 to D4 is set to a channel number in the Direct Channel Configuration Register.

**[ROUTE:]OPEN <channel\_list>** can be implemented by setting VLD\* false in either the Scan Channel Configuration Register or the Direct Control Register (whichever one closed the channel). It can also be implemented by toggling the DIR bit in the Status/Control Register.

For **[ROUTE:]SCAN <channel\_list>**, the complete scan list must be loaded in each module in a multiple-module configuration. The channel is set valid if it is in that module, and invalid in the other modules. The *channel list* is downloaded in the following way:

- Set CLR SCN in Scan Control Register to one, then back to zero, to clear the previous scan list.
- DIR in the Status/Control Register is set to false.
- Channel number is set in D0 to D4 in the Scan Channel Configuration Register.

The example below shows how to set a scan list for channels (@100,101,200,201):

- Write to the Scan Channel Configuration Register on card 1:

|                               |                                                       |
|-------------------------------|-------------------------------------------------------|
| VLD* true (0), 0000 to D4-D0  | <i>Sets channel 100</i>                               |
| VLD* true (0), 0001 to D4-D0  | <i>Sets channel 101</i>                               |
| VLD* false (1), XXXX to D4-D0 | <i>Reserves position in scan list for channel 200</i> |
| VLD* false (1), XXXX to D4-D0 | <i>Reserves position in scan list for channel 201</i> |

- Write to the Scan Channel Configuration Register on card 2:

|                               |                                                       |
|-------------------------------|-------------------------------------------------------|
| VLD* false (1), XXXX to D4-D0 | <i>Reserves position in scan list for channel 100</i> |
| VLD* false (1), XXXX to D4-D0 | <i>Reserves position in scan list for channel 101</i> |
| VLD* true (0), 0000 to D4-D0  | <i>Sets channel 200</i>                               |
| VLD* true (0), 0001 to D4-D0  | <i>Sets channel 201</i>                               |

The **[ROUTE:]SCAN:MODE VOLT | RES** is set with C0 in the Scan Channel Configuration Register or Direct Control Register.

|    |             |
|----|-------------|
| C0 |             |
| 0  | Volts       |
| 1  | 2-wire ohms |

**[ROUTE:]SCAN:PORT NONE | ABUS** is set with A\_D\* and B\_D\* on the Scan Channel Configuration or Direct Control Registers. Set both bits to one for ABUS and to zero for NONE.

**[ROUTE:]SETTLing[:TIME]** is set with the D3 to D0 bits in the Scan Channel Delay Register. The bits form a number <sup>n</sup> (<sup>n</sup> is between 0 and 16), and the delay is 2<sup>n</sup> μsec.

**SYSTEM** **SYSTEM:CDEscription?** is a READ on the Manufacturer ID Register.

**SYSTEM:CTYPe?** is a READ on the Device Type Register.

**SYSTEM:CPON** can be achieved by setting the DIR bit true in the Status/Control Register and setting VLD\* false. This opens all channels without a card reset.

**TRIGger** **TRIGger[:IMMediate]** is equivalent to writing a one to TRG INT in the Status Control Register. The register returns to zero after pulsing the channel.

**TRIGger:SOURce IMMEDIATE** and **TRIGger:SOURce DBUS** are executed with the IMM EN and DBS EN bits in the Scan Control Register.

**TRIGger:SOURce BUS** and **TRIGger:SOURce EXTERNAL** are not implemented at the register level. These commands both write to the TRG INT bit when they are active and a trigger occurs.

**TRIGger:SOURce HOLD** is not implemented at the register level. It is in the normal state when all trigger sources are disabled.





# Appendix C

## HP E1352A Multiplexer Error Messages

---

Table C-1 lists the error messages associated with the multiplexer modules programmed by SCPI. See your mainframe manual for a complete list.

**Table C-1. 32-Channel FET Multiplexer Error Messages**

| No.  | Title                                     | Potential Cause(s)                                                                                                                                           |
|------|-------------------------------------------|--------------------------------------------------------------------------------------------------------------------------------------------------------------|
| -211 | Trigger ignored                           | Trigger received when scan not enabled. Trigger received after scan complete. Trigger too fast.                                                              |
| -213 | Init ignored                              | Attempting to execute an INIT command when a scan is already in progress.                                                                                    |
| -224 | Illegal parameter                         | Attempting to execute a command with a parameter not applicable to the command.                                                                              |
| 1500 | External trigger source already allocated | Assigning an external trigger source to a switchbox when the trigger source has already been assigned to another switchbox.                                  |
| 2000 | Invalid card number                       | Addressing a module (card) in a switchbox that is not part of the switchbox.                                                                                 |
| 2001 | Invalid channel number                    | Attempting to address a channel of a module in a switchbox that is not supported by the module (e.g., channel 99 of a multiplexer module).                   |
| 2006 | Command not supported                     | Sending a command to a module (card) in a switchbox that is unsupported by the module.                                                                       |
| 2008 | Scan list not initialized                 | Executing INIT command with no scan <i>&lt;channel_list&gt;</i>                                                                                              |
| 2009 | Too many channels in channel list         | Attempting to address more channels than available in the switchbox.                                                                                         |
| 2010 | Scan mode not allowed on this card        | Attempting to execute a SCAN:MODE which is not supported.                                                                                                    |
| 2011 | Empty channel list                        | No valid channels in <i>&lt;channel_list&gt;</i>                                                                                                             |
| 2012 | Invalid channel range                     | Invalid channel(s) specified in SCAN <i>&lt;channel list&gt;</i> command. Attempting to begin scanning when no valid <i>&lt;channel_list&gt;</i> is defined. |
| 2017 | Incorrect ARM:COUNT                       | Attempting to run a downloaded scan list with ARM:COUNT set to value other than 1.                                                                           |
| 2600 | Function not supported on this card       | Sending a command to a module (card) in a switchbox that is not supported by the module or switchbox.                                                        |
| 2601 | Channel list required                     | Sending a command requiring a <i>&lt;channel_list&gt;</i> without the <i>&lt;channel_list&gt;</i> .                                                          |



- \*CLS, 70
- \*ESE, 70
- \*ESE?, 70
- \*ESR?, 70
- \*IDN?, 70
- \*OPC, 70
- \*OPC?, 70
- \*RCL, 70
- \*RST, 70 - 71
- \*SAV, 70
- \*SRE, 46, 70
- \*SRE?, 70
- \*STB?, 46, 70
- \*TRG, 70 - 71
- \*TST?, 70 - 71
- \*WAI, 70

### A

- A16 Address Space, 75
- Abbreviated Commands, 48
- ABORt Subsystem, 50, 71, 85
- Address
  - A16 address space, 75
  - base, 75
  - channel, 27 - 28
  - LADDR, 19
  - logical, 13, 18 - 19
  - mainframe, 14
  - primary, 14
  - registers, 75
  - scanning voltmeter, 14, 18 - 19
  - secondary, 13 - 14, 18
  - switch, setting, 19
  - switchbox, 14, 18
- Analog Bus
  - cable, 38
  - connector, 13, 24, 38
- ARM Subsystem, 51, 71
- ARM:COUNT, 33, 51, 85
- ARM:COUNT?, 51

### B

- Base Address, 75
- Bit Descriptions, register, 80
- Block Diagram, 12
- Boolean Command Parameters, 49

### C

- Cables
  - analog bus, 38
  - custom, 16
  - digital bus, 16, 24, 38
  - ribbon, 13
- Card ID, 20
- Card Numbers, 18, 27
- CAUTIONS, 17
- Certification, 5
- Channel
  - address, 27 - 28
  - advance triggering, 13, 15
  - closing, 16, 27, 30, 57
  - list, 27
  - lists, 59
  - numbers, 11
  - opening, 27, 58
  - query open/closed, 58 - 59
  - scanning, 59
  - scanning a range of, 32
  - scanning switchbox, 39, 60
  - selecting, 27
- Closing
  - channels, 16, 27, 30, 57
  - FETs, 29
  - tree isolation switches, 13, 62
- \*CLS, 70
- Command Reference, 47 - 72
- Commands
  - abbreviated, 48
  - IEEE 488.2, 47, 70
  - implied, 48
  - keyword, 48
  - linking, 49
  - optional, 48
  - optional parameters, 49
  - parameters, 49
  - quick reference, 71

- scanning switchbox channels, 39 - 40
- SCPI, 47
- SCPI format, 47
- separator, 48
- types, 47
- Comment sheet, reader, 9
- Common (\*) Commands, 47
  - \*CLS, 70
  - \*ESE, 70
  - \*ESR?, 70
  - format, 47
  - \*IDN?, 70
  - list of, 70
  - \*OPC, 70
  - \*OPC?, 70
  - quick reference, 71
  - \*RCL, 70
  - \*RST, 70 - 71
  - \*SAV, 70
  - \*SRE, 46, 70
  - \*SRE?, 70
  - \*STB?, 46, 70
  - \*TRG, 70 - 71
  - \*TST?, 70 - 71
  - \*WAI, 70
- Configuring
  - HP E1352A module, 17 - 26
  - scanning voltmeter, 38
- Conformity, declaration, 7
- Connecting
  - analog and digital bus cables, 38
  - external current sources, 31
  - field wiring, 22 - 23
  - multimeters, 24, 29
  - multiple modules together, 13
  - signal generators, 24
  - stand-alone multimeters, 13, 24
  - switchbox channels to tree terminals, 29
  - user inputs, 25
- Connections
  - analog bus, 13, 24, 38
  - digital bus, 24, 38
  - multimeter, 13, 24, 29, 38
  - scanning voltmeter, 13
  - terminal module, 13, 22
  - tree terminals, 13, 24
- Continuous Scans, 35, 54
- Current
  - maximum allowed, 17
  - sources, 31
- Custom Cables, 16

## D

- Declaration of conformity, 7
- Description, 11
- Device Type Register, 78, 80
- Diagram, block, 12
- Digital Bus, 15
  - cable, 16, 24, 38
  - handshake lines, 15
  - port, 16
  - triggering, 16, 44 - 45, 62, 68
- Direct Channel Configuration Register, 79, 83
- Direct Control Register, 79, 84
- Discrete Command Parameters, 49
- DISPlay Subsystem, 52 - 53, 71
- DISPlay:MONitor:CARD, 52
- DISPlay:MONitor[:STATe], 53, 85
- Documentation history, 6
- Downloading Scan List, 35 - 37, 59

## E

- Error
  - messages, 89 - 90
  - numbers, 89 - 90
  - queue, 66
- \*ESE, 70
- \*ESE?, 70
- \*ESR?, 70
- Event In Port, 15, 43, 68 - 69
- Executing Commands, 85
- External
  - current sources, 31
  - instruments, scanning with, 39, 42 - 44, 60
  - trigger inputs, 68
  - trigger port, 42 - 44
  - triggering, 15

## F

- Field Wiring, 22 - 23
- Format
  - common commands, 47
  - SCPI commands, 47

## G

- Getting Started, 11 - 16

## H

High-speed Operation, 13  
HP 3457A Digital Multimeter, 42 - 44, 60  
HP E1326B Multimeter, 45  
HP-IB  
    interface select code, 14  
    service request (SRQ), 46

## I

ID Register, 78, 80  
\*IDN?, 70  
IEEE 488.2 Commands  
    See Common (\*) Commands  
Implied Commands, 48  
Initial Operation, 16  
INITiate Subsystem, 54 - 55, 71  
INITiate:CONTinuous, 54, 85  
INITiate:CONTinuous?, 55  
INITiate[:IMMEDIATE], 55, 85  
Interrupt Line, 20  
IRQ, 20  
Isolation Jumper, 21

## J

Jumpers, isolation, 21

## K

Keywords, rules for use, 48

## L

LADDR, 19  
Linking Commands, 49  
Logical Address, 13, 18 - 19  
    changing, 19  
    factory setting, 19  
    multiple-module switchbox, 18  
    scanning voltmeter, 18 - 19  
    single-module switchbox, 18  
    switch, setting, 19  
Low-to-Guard Isolation Jumper, 21

## M

Mainframe Address, 14  
Making  
    continuous scans, 35, 54  
    measurements, 29, 31  
    multiple scans, 33  
Manufacturer ID Register, 78, 80  
Measurement Complete Port, 15

Measurements, 29

    ohms, 33  
    resistance, 31, 33  
    voltage, 32

Module

    block diagram, 12  
    card numbers, 18, 27  
    configuring, 17 - 26  
    connecting multiple, 13  
    connecting to multimeter, 13, 24, 29, 38, 45  
    connector pin-out, 25  
    description, 11  
    ID, 20  
    reset, 16  
    secondary address, 14  
    specifications, 73 - 74  
    terminal, 11

Multimeter

    connecting to E1352A, 13, 24, 29, 38, 45  
    connection points, 13  
    digital bus port, 16  
    primary address, 14  
    scanning voltmeter, 38, 45  
    synchronize E1352A to, 42 - 43

Multiple

    modules, 18, 27  
    scans, 33  
    SCPI commands, linking, 49

## N

Numeric Command Parameters, 49

## O

Ohms Measurements, 31, 33  
\*OPC, 70  
\*OPC?, 70  
Opening Channels, 27, 58  
Operation Status Register, 46, 64  
    bit value, 64  
    setting bit 8, 64  
Optional  
    command parameters, 49  
    commands, 48  
OUTPut Subsystem, 56, 71  
OUTPut[:STATe], 56, 85  
OUTPut[:STATe]?, 56

## P

Parameters, 49  
Pin-out Diagram, 25  
Polling, Status Register, 46  
Primary Address, 14  
Program Examples

- configuration commands required, 14
- making continuous scans, 35
- making multiple scans, 33
- ohms measurements by scanning, 33
- scan complete monitoring, 46
- scanning a switchbox, 36 - 37
- scanning using "Trig Out" and "Event In" ports, 43
- scanning using digital bus triggering, 44 - 45
- scanning using external instruments, 60
- scanning using scanning voltmeter, 45
- scanning using stand-alone multimeter, 44
- scanning with a multimeter, 38
- scanning with a scan list, 37
- scanning with external instruments, 42
- scanning without a scan list, 36
- verify initial operation, 16
- voltage measurements by scanning, 32

Programming Language, 16

## Q

### Query

- channel closure, 30
- error queue, 66
- number of scanning cycles, 51
- open/closed channels, 58 - 59
- scan mode, 61
- scanning state, 55
- settling time, 63
- trig out port state, 56
- trigger sources, 69

Quick Reference, commands, 71

## R

Range of Channels, 32

\*RCL, 70

READ Registers, 78

Reader comment sheet, 9

Register-Based Programming, 75 - 88

- executing commands, 85
- register addressing, 75
- register bit descriptions, 80
- register descriptions, 78

### Registers

- addressing, 75
- bit descriptions, 80
- descriptions, 78
- device type, 78, 80
- direct channel configuration, 79, 83
- direct control, 79, 84
- ID, 78, 80
- offset, 77
- operation status, 46, 64
- READ, 78
- scan channel configuration, 79, 83

scan channel delay, 79, 82

scan control, 79, 82

status, 46, 64

status/control, 79, 81

WRITE, 78

Resistance Measurements, 31

Ribbon Cable, 13

ROUTE: Subsystem, 57 - 63

ROUTE:CLOSE, 57, 85

ROUTE:CLOSE?, 58

ROUTE:OPEN, 58, 85

ROUTE:OPEN?, 59

ROUTE:SCAN, 59 - 60, 86

ROUTE:SCAN:MODE, 31, 61, 86

ROUTE:SCAN:MODE?, 61

ROUTE:SCAN:PORT, 62, 86

ABUS, 13, 29 - 30, 33, 62, 86

NONE, 30, 62, 86

ROUTE:SETTLing[:TIME], 62, 86

ROUTE:SETTLing[:TIME]?, 63

\*RST, 70 - 71

## S

Safety Warning, 17

Safety warnings, 6

\*SAV, 70

Scan Channel Configuration Register, 79, 83

Scan Channel Delay Register, 79, 82

Scan Complete Bit, 46

Scan Control Register, 79, 82

### Scanning

channels, 59

commands, 40

continuous cycles, 54

cycle, starting, 55

cycles (ARM), 51

cycles, continuous, 54

external instruments, 60

ohms measurements, 33

query state, 55

range of channels, 32

steps to take, 35

switchbox channels, 39

trigger sources, 39, 41, 68

using "Event In" ports, 43

using "Trig Out" ports, 43

using bus triggers, 69

using external triggers, 69

using scanning voltmeter configuration, 45

using stand-alone multimeters, 44

voltage measurements, 32

with downloaded scan list, 37

with external instruments, 39, 42

without downloaded scan list, 36

Scanning List, 13

- downloading, 35, 59
  - scanning with downloading, 37
  - scanning without downloading, 36
- Scanning Voltmeter
  - addressing, 19
  - analog bus connector, 13
  - card numbering, 19, 27
  - configuration, 13, 45
  - configuration with multimeter, 38, 45
  - continuous scanning, 54
  - setup, 14
- Schematic, simplified, 12
- SCPI Commands, 47
  - abbreviated, 48
  - ABORt subsystem, 50, 71
  - ARM subsystem, 51, 71
  - DISPlay subsystem, 52 - 53, 71
  - format used, 47
  - implied, 48
  - INTIate subsystem, 54 - 55, 71
  - linking, 49
  - long form, 48
  - optional, 48
  - optional parameters, 49
  - OUTPut subsystem, 56, 71
  - parameters, 49
  - quick reference, 71
  - reference, 49, 71
  - ROUte: subsystem, 57 - 63
  - scanning commands, 40
  - short form, 48
  - STATus subsystem, 64, 71
  - SYSTem subsystem, 65 - 66, 71
  - TRIGger subsystem, 67 - 69, 71
- Secondary Address, 13, 18
  - multiplexer, 14
  - switchbox, 14
- Selecting Channels, 27
- Service Request (SRQ), 46
- Setting
  - address switch, 19
  - card ID switch, 20
  - scanning cycles, 51
- Shock Hazard, 17
- Signal Generators, connecting, 24
- Specifications, 73 - 74
- \*SRE, 46, 70
- \*SRE?, 70
- Standard Commands for Programmable Instruments
  - See SCPI Commands
- Static Electricity, 17
- Status Register, 46, 64
  - polling, 46
- STATus Subsystem, 64, 71
- Status/Control Register, 79, 81
- STATus:OPERation:ENABle, 46, 64
- STATus:OPERation[:EVENT]?, 46, 64
- \*STB?, 46, 70
- Switchbox
  - addressing, 14, 18
  - card numbering, 18, 27
  - channels to tree terminals, 29
  - configuration, 13
  - continuous scanning, 54
  - description of, 14
  - errors, 66
  - scanning, 36 - 37
  - scanning channels, 39, 60
  - scanning range of channels, 32
  - secondary address, 14
  - setup, 14
- Switches
  - card ID, 20
  - interrupt line, 20
  - logical address, 19
  - tree isolation, 13, 29 - 30, 62
- Synchronize E1352A to HP 3457A multimeter, 42
  - E1352A to HP 3457A multimeter, 43
- SYSTem Subsystem, 65 - 66, 71
- SYSTem:CDEscription?, 65, 87
- SYSTem:CPON, 65, 87
- SYSTem:CTYPe?, 66, 87
- SYSTem:ERRor?, 66

**T**

- Terminal Block
  - See Terminal Module
- Terminal Module, 11
  - connections, 13, 22
  - wiring, 23
  - wiring guidelines, 22
- Tree Isolation Switch
  - closing FETs, 29
  - disabling, 30
- Tree Terminals, 13
  - connecting to multimeter, 31
  - connecting to switchbox channels, 29
  - connections, 24
- \*TRG, 70 - 71
- Trig Out Port, 42 - 43, 56
- TRIGger Subsystem, 67 - 69, 71
- TRIGger:SOURce, 68
  - BUS, 32, 68, 87
  - DBUS, 13, 16, 35, 68, 87
  - EXTeRnal, 32, 68, 87
  - HOLD, 68, 87
  - IMMEDIATE, 13, 35, 68, 87
- TRIGger:SOURce?, 69
- TRIGger[:IMMEDIATE], 67, 87
- Triggering, 15
  - channel advance, 13, 15

- delay, 62
- digital bus, 16, 44 - 45, 68
- external inputs, 68
- source, 13, 39, 41, 68
- sources, 68
- \*TST?, 70 - 71

## U

Understanding the HP E1352A, 39 - 46

Using

- bus triggers, 68
- external trigger inputs, 68
- HP 3457A multimeter, 42 - 44, 60
- HP E1326B multimeter, 45
- scan complete bit, 46
- scanning trigger sources, 39
- scanning voltmeter configuration, 45
- stand-alone multimeters, 44
- the HP E1352A, 27 - 38

## V

Voltage

- maximum allowed, 17
- measurement, 29, 32

Voltmeter Complete Port, 43 - 44

VXIbus

- backplane, 15
- instrument description, 13

## W

\*WAI, 70

WARNINGS, 6, 17

Warranty, 5

Wiring

- terminal module, 23

Wiring, terminal module, 22 - 23

WRITE Registers, 78